



**Powerware® 9125 Two-in-One UPS
2500/3000 VA
User's Guide**

Class A EMC Statements

FCC Part 15

NOTE This equipment has been tested and found to comply with the limits for a Class A digital device, pursuant to part 15 of the FCC Rules. These limits are designed to provide reasonable protection against harmful interference when the equipment is operated in a commercial environment. This equipment generates, uses, and can radiate radio frequency energy and, if not installed and used in accordance with the instruction manual, may cause harmful interference to radio communications. Operation of this equipment in a residential area is likely to cause harmful interference in which case the user will be required to correct the interference at his own expense.

ICES-003

This Class A Interference Causing Equipment meets all requirements of the Canadian Interference Causing Equipment Regulations ICES-003.

Cet appareil numérique de la classe A respecte toutes les exigences du Règlement sur le matériel brouilleur du Canada.

EN 50091-2

Some configurations are classified under EN 50091-2 as "Class-A UPS for Unrestricted Sales Distribution." For these configurations, the following applies:

WARNING This is a Class A-UPS Product. In a domestic environment, this product may cause radio interference, in which case, the user may be required to take additional measures.

Powerware, ABM, LanSafe, and FERRUPS are registered trademarks and X-Slot and ConnectUPS are trademarks of Eaton Power Quality Corporation. Modbus is a registered trademark of Modicon. AS/400 is a registered trademark of International Business Machines Corp.

©Copyright 2004–2005 Eaton Corporation, Raleigh, NC, USA. All rights reserved. No part of this document may be reproduced in any way without the express written approval of Eaton Corporation.

Requesting a Declaration of Conformity

Units that are labeled with a CE mark comply with the following harmonized standards and EU directives:

- Harmonized Standards: EN 50091-1-1 and EN 50091-2; IEC 60950 Third Edition
- EU Directives: 73/23/EEC, Council Directive on equipment designed for use within certain voltage limits
93/68/EEC, Amending Directive 73/23/EEC
89/336/EEC, Council Directive relating to electromagnetic compatibility
92/31/EEC, Amending Directive 89/336/EEC relating to EMC

The EC Declaration of Conformity is available upon request for products with a CE mark. For copies of the EC Declaration of Conformity, contact:

Eaton Power Quality Oy
Koskelontie 13
FIN-02920 Espoo
Finland
Phone: +358-9-452 661
Fax: +358-9-452 665 68

Special Symbols

The following are examples of symbols used on the UPS or accessories to alert you to important information:



RISK OF ELECTRIC SHOCK - Indicates that a risk of electric shock is present and the associated warning should be observed.



CAUTION: REFER TO OPERATOR'S MANUAL - Refer to your operator's manual for additional information, such as important operating and maintenance instructions.



RJ-45 RECEPTACLE - For 230V models only: this receptacle provides network interface connections. Do not plug telephone or telecommunications equipment into this receptacle.



This symbol indicates that you should not discard the UPS or the UPS batteries in the trash. This product contains sealed, lead-acid batteries and must be disposed of properly. For more information, contact your local recycling/reuse or hazardous waste center.



This symbol indicates that you should not discard waste electrical or electronic equipment (WEEE) in the trash. For proper disposal, contact your local recycling/reuse or hazardous waste center.

Table of Contents

- 1 Introduction 1**
- 2 Safety Warnings 3**
- 3 Installation 15**
 - Inspecting the Equipment 15
 - Connecting the UPS Internal Battery 16
 - UPS Setup 16
 - Rack-Mount Setup 17
 - Tower Setup 18
 - Extended Battery Module Installation 22
 - Plug-Receptacle UPS Installation 25
 - Hardwired UPS Installation 27
 - Remote Emergency Power-off Installation 31
 - UPS Rear Panels 33
- 4 Operation 35**
 - Turning the UPS On 35
 - Starting the UPS on Battery 35
 - Turning the UPS Off 36
 - Initiating the Self-Test 36
 - Operating Modes 37
 - Normal Mode 38
 - Battery Mode 39
 - Bypass Mode 40
 - Standby Mode 40
- 5 Configuration 41**
- 6 Additional UPS Features 45**
 - X-Slot Cards 45
 - Single-Port Card 46
 - Network Transient Protector 49
 - Load Segments 50

7	UPS Maintenance	51
	UPS and Battery Care	51
	Storing the UPS and Batteries	51
	When to Replace Batteries	52
	Replacing Batteries	52
	How to Replace UPS Internal Batteries	53
	How to Replace Extended Battery Modules	55
	Testing New Batteries	56
	Recycling the Used Battery or UPS	57
8	Specifications	59
9	Troubleshooting	63
	Audible Alarms and UPS Conditions	63
	Silencing an Audible Alarm	63
	Service and Support	66
10	Warranty	67
	Two-Year Limited Warranty (US and Canada)	67
	Ten-Year Pro-Rated Limited Warranty (US and Canada)	69
	Load Protection Guarantee (US and Canada)	71

Chapter 1 Introduction

The Powerware® 9125 uninterruptible power system (UPS) protects your sensitive electronic equipment from the most common power problems including power failures, power sags, power surges, brownouts, line noise, high voltage spikes, frequency variations, switching transients, and harmonic distortion.

Power outages can occur when you least expect it and power quality can be erratic. These power problems have the potential to corrupt critical data, destroy unsaved work sessions, and damage hardware — causing hours of lost productivity and expensive repairs.

With the Powerware 9125, you can safely eliminate the effects of power disturbances and guard the integrity of your equipment. Figure 1 shows the Powerware 9125 UPS with an optional Extended Battery Module (EBM).

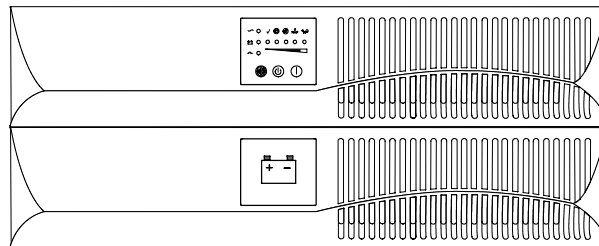

Figure 1. The Powerware 9125 UPS with Optional EBM

Providing outstanding performance and reliability, the Powerware 9125's unique benefits include the following:

- Online UPS design with pure sine wave output. The UPS filters and regulates incoming AC power and provides consistent power to your equipment without draining the battery.
- 2U rack height that conserves valuable rack space.
- Two-in-one form factor for using the UPS in a rack-mount configuration or as a standalone cabinet.
- ABM® technology that uses advanced battery management to increase battery service life, optimize recharge time, and provide a warning before the end of useful battery life.
- Hours of extended runtime with up to four EBMs.

- Start-on-battery capability for powering up the UPS even if utility power is not available.
- Hot-swappable batteries that simplify maintenance by allowing you to replace batteries safely without powering down the critical load.
- Emergency shutdown control through the remote emergency power-off (REPO) port.
- Optional X-Slot™ cards with enhanced communication capabilities for increased power protection and control.
- Network transient protector that guards your network communications equipment from surges. Low voltage models can also protect modems, fax machines, or other telecommunications equipment.
- Advanced power management with the Software Suite CD for graceful shutdowns and power monitoring.
- Sequential shutdown and load management through separate receptacle groups, called load segments.
- Flash memory provides easy upgrades or reconfiguration capability without requiring a service call.
- Backed by worldwide agency approvals.

IMPORTANT SAFETY INSTRUCTIONS SAVE THESE INSTRUCTIONS

This manual contains important instructions that you should follow during installation and maintenance of the UPS and batteries. Please read all instructions before operating the equipment and save this manual for future reference.

DANGER



This UPS contains **LETHAL VOLTAGES**. All repairs and service should be performed by **AUTHORIZED SERVICE PERSONNEL ONLY**. There are **NO USER SERVICEABLE PARTS** inside the UPS.

WARNING



- This UPS contains its own energy source (batteries). The output receptacles may carry live voltage even when the UPS is not connected to an AC supply.
 - For 220–240V models, the output receptacles may remain electrically live. If the input power source in your application is wired line-to-neutral (as in most European applications), the voltage to the output receptacles is 0V. With line-to-line input wiring, the voltage to the output receptacles is 110–120V (measured from line-to-ground or line-to-neutral, depending on the UPS wiring).
 - Do not remove or unplug the input cord when the UPS is turned on. This removes the safety ground from the UPS and the equipment connected to the UPS.
 - To reduce the risk of fire or electric shock, install this UPS in a temperature and humidity controlled, indoor environment, free of conductive contaminants. Ambient temperature must not exceed 40°C (104°F). Do not operate near water or excessive humidity (95% maximum).
 - To comply with international standards and wiring regulations, the total equipment connected to the output of this UPS must not have an earth leakage current greater than 1.5 milliamperes.
 - For UPS models with hardwired outputs, overcurrent protection for the output AC circuit(s) is to be provided by others.
 - For UPS models with hardwired outputs, suitably rated disconnect switches for the output AC circuit(s) are to be provided by others.
-



CAUTION

- Batteries can present a risk of electrical shock or burn from high short-circuit current. Observe proper precautions. Servicing should be performed by qualified service personnel knowledgeable of batteries and required precautions. Keep unauthorized personnel away from batteries.
- Proper disposal of batteries is required. Refer to your local codes for disposal requirements.
- Never dispose of batteries in a fire. Batteries may explode when exposed to flame.

Sikkerhedsanvisninger

VIGTIGE SIKKERHEDSANVISNINGER GEM DISSE ANVISNINGER DENNE BRUGERVEJLEDNING INDEHOLDER VIGTIGE SIKKERHEDSANVISNINGER



FARE

Denne UPS indeholder LIVSFARLIG HØJSPÆNDING. Alle reparationer og vedligeholdelse bør kun udføres af en AUTORISERET SERVICE TEKNIKER. Ingen af UPS'ens indvendige dele kan repareres af brugeren.



ADVARSEL!

- Denne UPS indeholder egen energiforsyning (batterier). Udgangsnetstikkene kan lede strøm, selv når UPS'en ikke er tilsat en AC-energikilde.
- Netledningen må ikke fjernes og stikket må ikke trækkes ud, mens UPS'en er tændt. Dette fjerner sikkerhedsjorden fra UPS'en og fra det udstyr, der er sat til.
- Installer denne UPS i et temperatur- og fugtighedskontrolleret indendørsmiljø, frit for ledende forureningsstoffer for at formindske risikoen for brand og elektrisk stød. Rumtemperaturen må ikke overstige 40°C. UPS'en bør ikke betjenes nær vand eller høj fugtighed (maksimalt 95%).
- I overensstemmelse med internationale normer og bestemmelser for el-installation må det udstyr, der er forbundet til udgangen af denne UPS, tilsammen ikke overskride en jordafdelingspænding på mere end 1,5 milliamperere.
- For UPS systemer med hårdledningsudgange, skal overstrømsbeskyttelse for vekslestrømmens udgangskredsløb forsynes af andre.
- For UPS systemer med hårdledningsudgange, skal egnede, nominelle afbryderkontakter for vekslestrømmens udgangskredsløb forsynes af andre.



ADVARSEL

- Batterier kan udgøre en fare for elektrisk stød eller forbrændinger forårsaget af høj kortslutningsspænding. De korrekte forholdsregler bør overholdes.
- Korrekt bortskaffelse af batterier er påkrævet. Overhold gældende lokale regler for bortskaffelsesprocedurer.
- Skaf dig aldrig af med batterierne ved at brænde dem. Batterierne kan eksplodere ved åben ild.

Belangrijke Veiligheidsinstructies

BELANGRIJKE VEILIGHEIDSINSTRUCTIES BEWAAR DEZE INSTRUCTIES DEZE HANDLEIDING BEVAT BELANGRIJKE VEILIGHEIDSINSTRUCTIES



GEVAAR

Deze UPS bevat LEVENSGEVAARLIJKE ELEKTRISCHE SPANNING. Alle reparaties en onderhoud dienen UITSLUITEND DOOR ERKEND SERVICEPERSONEEL te worden uitgevoerd. Er bevinden zich GEEN ONDERDELEN in de UPS die DOOR DE GEBRUIKER kunnen worden GEREPAREERD.



WAARSCHUWING

- Deze UPS bevat zijn eigen energiebron (batterijen). De uitgangsaansluitingen kunnen onder spanning staan wanneer de UPS niet op een wisselstroom voeding is aangesloten.
- Verwijder de ingang snoer niet of haal de stekker van de ingang snoer er niet uit terwijl de UPS aan staat. Hierdoor zou de UPS en uw aangesloten apparatuur geen aardebeveiliging meer hebben.
- Teneinde de kans op brand of elektrische schok te verminderen dient deze UPS in een gebouw met temperatuur- en vochtigheidsregeling te worden geïnstalleerd, waar geen geleidende verontreinigingen aanwezig zijn. De omgevingstemperatuur mag 40°C niet overschrijden. Niet gebruiken in de buurt van water of bij zeer hoge vochtigheid (max. 95%).
- Om aan de internationale normen en bedravingsvoorschriften te voldoen mag de gehele apparatuur die op de uitgang van deze UPS is aangesloten, geen aardlekstroom van meer dan 1,5 milliampère hebben.
- Voor UPS systemen met vast-bedrade uitgangen, moet de overstroombeveiliging voor wisselstroom uitvoercircuit(s) door anderen worden geleverd.
- Voor UPS systemen met vast-bedrade uitgangen, moeten de juiste hoofdschakelaars voor wisselstroom uitvoercircuit(s) door anderen worden geleverd.



OPGELET

- Batterijen kunnen gevaar voor elektrische schok of brandwonden veroorzaken als gevolg van un hoge kortsluitstroom. Volg de desbetreffende aanwijzingen op.
- De batterijen moeten op de juiste wijze worden opgeruimd. Raadpleeg hiervoor uw plaatselijke voorschriften.
- Nooit batterijen in het vuur gooien. De batterijen kunnen ontploffen.

Tarkeita Turvaohjeita

TÄRKEITÄ TURVAOHJEITA - SUOMI SÄILYTÄ NÄMÄ OHJEET TÄMÄ OPAS SISÄLTÄÄ TÄRKEITÄ TURVAOHJEITA



VAARA

Tämä UPS sisältää HENGENVAARALLISIA JÄNNITTEITÄ. Kaikki korjaukset ja huollot on jätettävä VAIN VALTUUTETUN HUOLTOHENKILÖN TOIMEKSI. UPS ei sisällä MITÄÄN KÄYTTÄJÄN HUOLLETTAVIA OSIA.



VAROITUS

- Tämä UPS sisältää oman energialähteen (akuston). Ulostuloliittimissä voi olla jännite, kun UPS ei ole liitettynä verkkojännitteeseen.
- Älä poista tai irrota sisääntulojohtoa, kun UPS on kytkettynä. Tämä poistaa turvamaadoituksen UPS-laitteesta ja siihen liitetystä laitteistosta.
- Vähentääksesi tulipalon ja sähköiskun vaaraa asenna tämä UPS sisätiloihin, joissa lämpötila ja kosteus on säädettävissä ja joissa ei ole virtaa johtavia epäpuhtauksia. Ympäristön lämpötila ei saa ylittää 40 °C. Älä käytä lähellä vettä ja vältä kosteita tiloja (95 % maksimi).
- Kansainväliset normit ja johdotusmääräykset vaativat, että kaikkien tämän UPS-laitteen ulostulokytkentöjen yhteinen maavuotovirta ei ylitä 1,5 milliampeeria (mA).
- UPS-järjestelmissä kiintealla asennuksella: kuormana olevien laitteiden ylivirtasuojaus ja erotuskytkimet tulee toteuttaa kuormapiireissa.



VARO

- Akusto saattaa aiheuttaa sähköiskun tai syttyä tuleen, jos akusto kytketään oikosulkuun. Noudata asianmukaisia ohjeita.
- Akusto täytyy hävittää säädösten mukaisella tavalla. Noudata paikallisia määräyksiä.
- Älä koskaan heitä akkuja tuleen. Ne voivat räjähtää.

Consignes de sécurité

CONSIGNES DE SÉCURITÉ IMPORTANTES CONSERVER CES INSTRUCTIONS CE MANUEL CONTIENT DES CONSIGNES DE SÉCURITÉ IMPORTANTES



DANGER!

Cet onduleur contient des TENSIONS MORTELLES. Toute opération d'entretien et de réparation doit être EXCLUSIVEMENT CONFIEE A UN PERSONNEL QUALIFIE AGRÉÉ. AUCUNE PIÈCE RÉPARABLE PAR L'UTILISATEUR ne se trouve dans l'onduleur.



AVERTISSEMENT!

- Cet onduleur renferme sa propre source d'énergie (batteries). Les prises de sortie peuvent être sous tension même lorsque l'onduleur n'est pas branché sur le secteur.
- Ne pas retirer le cordon d'alimentation lorsque l'onduleur est sous tension sous peine de supprimer la mise à la terre de l'onduleur et du matériel connecté.
- Pour réduire les risques d'incendie et de décharge électrique, installer l'onduleur uniquement à l'intérieur, dans un lieu dépourvu de matériaux conducteurs, où la température et l'humidité ambiantes sont contrôlées. La température ambiante ne doit pas dépasser 40 °C. Ne pas utiliser à proximité d'eau ou dans une atmosphère excessivement humide (95 % maximum).
- Afin d'être conforme aux normes et règlements internationaux de câblage, le courant de fuite à la terre de la totalité du matériel branché sur la sortie de l'onduleur ne doit pas dépasser 1,5 mA.
- Pour les modèles UPS ayant des sorties câblées, la protection contre une surintensité pour le(s) circuit(s) de sortie de courant alternatif doit être fournie par un autre fournisseur.
- Pour les modèles UPS ayant des sorties câblées, les interrupteurs de déconnexion convenables pour le(s) circuit(s) de sortie de courant alternatif doivent être fournis par un autre fournisseur.



ATTENTION!

- Les batteries peuvent présenter un risque de décharge électrique ou de brûlure par des courts-circuits de haute intensité. Prendre les précautions nécessaires.
- Une mise au rebut réglementaire des batteries est obligatoire. Consulter les règlements en vigueur dans votre localité.
- Ne jamais jeter les batteries au feu. L'exposition aux flammes risque de les faire exploser.

Sicherheitswarnungen

WICHTIGE SICHERHEITSANWEISUNGEN AUFBEWAREN

Dieses Handbuch enthält wichtige Hinweise, welche Sie bei der Installation und Wartung die USV beachten sollten. Bitte lesen Sie alle Anweisungen des Handbuches bevor sie mit dem Gerät arbeiten. Bewahren Sie das Handbuch zum Nachlesen auf.

WARNUNG



Die USV führt lebensgefährliche Spannungen. Alle Reparatur- und Wartungsarbeiten sollten nur von Kundendienstfachleuten durchgeführt werden. Die USV enthält keine vom Benutzer zu wartenden Komponenten.

ACHTUNG



- Diese USV ist mit einer eigenen Energiequelle (Batterie) ausgestattet. An den Ausgangssteckdosen kann auch dann Spannung anliegen, wenn die USV nicht an einer Wechselspannungsquelle angeschlossen ist.
- Bei Modellen mit 220–240 Volt können die Ausgangssteckverbinder stromführend bleiben. Wenn die Eingangsstromquelle in Ihrer Anlage mit Masseleitung verkabelt ist (wie in den meisten europäischen Anlagen), beträgt die Spannung an den Ausgangssteckverbindern 0 Volt. Bei einer Verkabelung mit Außenleitern beträgt die Spannung an den Ausgangssteckverbindern 110–120 Volt (gemessen von Leitung zu Masse oder Leitung zu Masseleiter, abhängig von der UPS (USV)-Verkabelung).
- Das Eingangskabel nicht entfernen oder abziehen, während die USV eingeschaltet ist, weil hierdurch die Sicherheitserdung von der USV und den daran angeschlossenen Geräten entfernt wird.
- Um die Brand- oder Elektroschockgefahr zu verringern, diese USV nur in Gebäuden mit kontrollierter Temperatur und Luftfeuchtigkeit installieren, in denen keine leitenden Schmutzstoffen vorhanden sind. Die Umgebungstemperatur darf 40°C nicht übersteigen. Die USV nicht in der Nähe von Wasser oder in extrem hoher Luftfeuchtigkeit (max. 95 %) betreiben.
- Um internationale Normen und Verdrahtungsvorschriften zu erfüllen, dürfen die an den Ausgang dieser USV angeschlossenen Geräte zusammen einen Erdableitstrom von insgesamt 1,5 Milliampere nicht überschreiten.
- Für UPS-Systeme mit festverdrahteten Eingängen muß der Überstromschutz für die Ausgangswechselstromkreise anderweitig bereitgestellt werden.
- Für UPS-Systeme mit festverdrahteten Ausgängen müssen Trennschalter für die Ausgangswechselstromkreise mit passendem Nennwert anderweitig bereitgestellt werden.



VORSICHT!

- Batterien können aufgrund des hohen Kurzschlußstroms Elektroschocks oder Verbrennungen verursachen. Die entsprechenden Vorsichtsmaßnahmen sind unbedingt zu beachten. Wartungsarbeiten sollten nur von qualifiziertem Fachpersonal, welches sich mit dieser Art von Batterien und den entsprechenden Sicherheitsvorkehrungen auskennt, durchgeführt werden. Bitte halten Sie unqualifiziertes Personal von den Batterien fern.
- Die Batterien müssen ordnungsgemäß entsorgt werden. Hierbei sind die örtlichen Bestimmungen zu beachten.
- Batterien niemals verbrennen, da sie explodieren können.

Avvisi di sicurezza

IMPORTANTI ISTRUZIONI DI SICUREZZA CONSERVARE QUESTE ISTRUZIONI QUESTO MANUALE CONTIENE IMPORTANTI ISTRUZIONI DI SICUREZZA



PERICOLO

La TENSIONE contenuta in questo gruppo statico di continuità è LETALE. Tutte le operazioni di riparazione e di manutenzione devono essere effettuate ESCLUSIVAMENTE DA PERSONALE TECNICO AUTORIZZATO. All'interno del gruppo statico di continuità NON vi sono PARTI RIPARABILI DALL'UTENTE.



AVVERTENZA

- Questo gruppo statico di continuità contiene una fonte di energia autonoma (le batterie). Le prese di uscita possono condurre tensione energizzata quando il gruppo statico di continuità non è collegato con una fonte di alimentazione a corrente alternata.
- Non rimuovere nè scollegare il cavo di ingresso quando il gruppo statico di continuità è acceso poichè in tal modo si disattiverrebbe il collegamento a terra di sicurezza del gruppo statico di continuità e dell'apparecchiatura ad esso collegata.
- Per ridurre il rischio di incendio o di scossa elettrica, installare il gruppo statico di continuità in un ambiente interno a temperatura ed umidità controllata, privo di agenti contaminanti conduttivi. La temperatura ambiente non deve superare i 40°C. Non utilizzare l'unità in prossimità di acqua o in presenza di umidità eccessiva (95% max).
- Per conformità con gli standard internazionali e con le norme in merito al cablaggio, tutta l'apparecchiatura collegata con l'uscita del gruppo statico di continuità non deve avere una corrente di dispersione di terra superiore a 1,5 milliampere.
- Nei sistemi UPS provvisti di uscite cablate, i dispositivi di protezione da sovracorrente per il/i circuito/i a corrente alternata in uscita devono essere forniti da terzi.
- Nei sistemi UPS provvisti di uscite cablate, i sezionatori di corrente nominale adeguata per il/i circuito/i a corrente alternata in uscita devono essere forniti da terzi.

**ATTENZIONE**

- Le batterie possono presentare rischio di scossa elettrica o di ustioni provocate da alta corrente dovuta a corto circuito. Osservare le apposite istruzioni.
- Le batterie devono essere smaltite in modo corretto. Per i requisiti di smaltimento fare riferimento alle disposizioni locali.
- Non gettare mai le batterie nel fuoco poichè potrebbero esplodere se esposte alle fiamme.

Viktig Sikkerhetsinformasjon**FARLIG**

Denne UPS'en inneholder LIVSFARLIGE SPENNINGER. All reparasjon og service må kun utføres av AUTORISERT SERVICEPERSONALE. BRUKERE KAN IKKE UTFØRE SERVICE PÅ NOEN AV DELENE i UPS'en.

**FARLIG**

- Denne UPS'en har en egen energikilde (batterier). Stikkontaktene kan være strømførende selv om UPS'en ikke er tilsluttet en vekselstrømforsyning.
- Strømforsyningskabelen må ikke fjernes eller trekkes ut når UPS'en er på, slik at ikke sikkerhetsjordingen fjernes fra UPS'en og det utstyret som er forbundet med den.
- For å redusere fare for brann eller elektriske støt, bør denne UPS'en installeres i et innendørs miljø med kontrollert temperatur og luftfuktighet som er fritt for ledende, forurensende stoffer. Romtemperaturen må ikke overskride 40°C. Den må ikke brukes i nærheten av vann eller ved meget høy luftfuktighet (95% maks.).
- Alt utstyr som er forbundet med utgangen av denne UPS'en må ikke ha en sterkere total lekkasjestrøm enn 1,5 milliampere for å være i overensstemmelse med internasjonale standarder og forkablingsbestemmelser.
- For UPS systemer med fastkoplede uttak, må overstrømvern for vekselstrømuttak(ene) stilles til rådighet av andre.
- For UPS systemer med fastkoplede uttak, må passende utkoplingsbrytere for vekselstrømuttak(ene) stilles til rådighet av andre.

**FORSIKTIG**

- Batterier kan forårsake elektriske støt eller forbrenning på grunn av høy kortslutningsstrøm. Følg instruksene.
- Batterier må fjernes på korrekt måte. Se lokale forskrifter vedrørende krav om fjerning av batterier.
- Kast aldri batterier i flammer, da de kan eksplodere, hvis de utsettes for åpen ild.

Regulamentos de Segurança

INSTRUÇÕES DE SEGURANÇA IMPORTANTES GUARDE ESTAS INSTRUÇÕES ESTE MANUAL CONTÉM INSTRUÇÕES DE SEGURANÇA IMPORTANTES



CUIDADO

A UPS contém VOLTAGEM MORTAL. Todos os reparos e assistência técnica devem ser executados SOMENTE POR PESSOAL DA ASSISTÊNCIA TÉCNICA AUTORIZADO. Não há nenhuma PEÇA QUE POSSA SER REPARADA PELO USUÁRIO dentro da UPS.



ADVERTÊNCIA

- Esta UPS contém sua própria fonte de energia (baterias). Os receptáculos de saída podem conter voltagem ativa quando a UPS não se encontra conectada a uma fonte de alimentação de corrente alternada.
- Não remova ou desconecte o cabo de entrada quando a UPS estiver ligada. Isto removerá o aterramento de segurança da UPS e do equipamento conectado.
- Para reduzir o risco de incêndios ou choques elétricos, instale a UPS em ambiente interno com temperatura e umidade controladas e livres de contaminadores condutíveis. A temperatura ambiente não deve exceder 40°C. Não opere próximo a água ou em umidade excessiva (máx: 95%).
- Para estar de acordo com os padrões internacionais e os regulamentos de fiação, o equipamento total conectado à saída desta UPS não deve ter uma corrente de fuga à terra maior que 1,5 miliampères.
- Para sistemas UPS com saídas conectadas, a proteção de sobrecarga para circuitos de saída de corrente alternada deve ser fornecida por outros.
- Para sistemas UPS com saídas conectadas, interruptores de desconexão devidamente qualificados para circuitos de saída de corrente alternada devem ser fornecidos por outros.



PERIGO

- As baterias podem apresentar o risco de choque elétrico, ou queimaduras provenientes de alta corrente de curto-circuito. Observe as instruções adequadas.
- Siga as instruções apropriadas ao desfazer-se das baterias. Consulte os códigos do local para maiores informações sobre os regulamentos de descarte de produtos.
- Nunca jogue as baterias no fogo, porque há risco de explosão.

Предупреждения по мерам безопасности

ВАЖНЫЕ УКАЗАНИЯ ПО МЕРАМ БЕЗОПАСНОСТИ СОХРАНИТЕ ЭТИ УКАЗАНИЯ ДАННОЕ РУКОВОДСТВО СОДЕРЖИТ ВАЖНЫЕ УКАЗАНИЯ ПО МЕРАМ БЕЗОПАСНОСТИ

ОПАСНО



В данном ИБП имеются СМЕРТЕЛЬНО ОПАСНЫЕ НАПРЯЖЕНИЯ. Все работы по ремонту и обслуживанию должны выполняться ТОЛЬКО УПОЛНОМОЧЕННЫМ ОБСЛУЖИВАЮЩИМ ПЕРСОНАЛОМ. Внутри ИБП нет узлов, ОБСЛУЖИВАЕМЫХ ПОЛЬЗОВАТЕЛЕМ.

ПРЕДУПРЕЖДЕНИЕ



- Данный ИБП содержит собственные источники энергии (аккумуляторы). На выходных розетках может иметься напряжение, даже когда ИБП не подключен к сети переменного тока.
- Не отсоединяйте сетевой шнур и не извлекайте его вилку из розетки при включенном ИБП. При этом защитное заземление отключается от ИБП и от оборудования, подключенного к ИБП.
- Для снижения опасности пожара или поражения электрическим током устанавливайте ИБП в закрытом помещении с контролируемой температурой и влажностью, в котором отсутствуют проводящие загрязняющие вещества. Температура окружающего воздуха не должна превышать 40°C. Не эксплуатируйте устройство около воды или в местах с повышенной влажностью (макс. 95%).
- Для обеспечения соблюдения требований международных стандартов и требований к разводке электрических цепей, суммарная величина тока утечки на землю всего оборудования, подключенного к выходу ИБП, не должна превышать 1,5 миллиампера.

ОСТОРОЖНО



- Аккумуляторы могут вызвать опасность поражения электрическим током или ожога от тока короткого замыкания. Соблюдайте соответствующие меры предосторожности.
- Необходимо соблюдать правила утилизации аккумуляторов. Обратитесь к местным нормативным актам за информацией о требованиях к утилизации.
- Никогда не бросайте аккумуляторы в огонь. Аккумуляторы могут взорваться под воздействием огня.

Advertencias de Seguridad

INSTRUCCIONES DE SEGURIDAD IMPORTANTES GUARDE ESTAS INSTRUCCIONES ESTE MANUAL CONTIENE INSTRUCCIONES DE SEGURIDAD IMPORTANTES

PELIGRO



Este SIE contiene VOLTAJES MORTALES. Todas las reparaciones y el servicio técnico deben ser efectuados SOLAMENTE POR PERSONAL DE SERVICIO TÉCNICO AUTORIZADO. No hay NINGUNA PARTE QUE EL USUARIO PUEDA REPARAR dentro del SIE.

ADVERTENCIA



- Este SIE contiene su propia fuente de energía (las baterías). Los receptáculos de salida pueden transmitir corriente eléctrica aun cuando el SIE no esté conectado a un suministro de corriente alterna (c.a.).
- No retire o desenchufe el cable de entrada mientras el SIE se encuentre encendido. Esto suprime la descarga a tierra de seguridad del SIE y de los equipos conectados al SIE.
- Para reducir el riesgo de incendio o de choque eléctrico, instale este SIE en un lugar cubierto, con temperatura y humedad controladas, libre de contaminantes conductores. La temperatura ambiente no debe exceder los 40°C. No trabaje cerca del agua o con humedad excesiva (95% máximo).
- Para cumplir con los estándares internacionales y las normas de instalación, la totalidad de los equipos conectados a la salida de este SIE no debe tener una intensidad de pérdida a tierra superior a los 1,5 miliamperios.
- Para los sistemas UPS con salidas cableadas permanentemente, la protección contra exceso de corriente para el/los circuito(s) de CA de salida será suministrada por terceros.
- Para los sistemas UPS con salidas cableadas permanentemente, los interruptores de desconexión debidamente clasificados para el/los circuito(s) de CA de salida serán suministrados por terceros.

PRECAUCIÓN



- Las baterías pueden presentar un riesgo de descargas eléctricas o de quemaduras debido a la alta corriente de cortocircuito. Preste atención a las instrucciones correspondientes.
- Es necesario desechar las baterías de un modo adecuado. Consulte las normas locales para conocer los requisitos pertinentes.
- Nunca deseche las baterías en el fuego. Las baterías pueden explotar si se las expone a la llama.

Säkerhetsföreskrifter

VIKTIGA SÄKERHETSFÖRESKRIFTER SPARA DESSA FÖRESKRIFTER DENNA BRUKSANVISNING INNEHÅLLER VIKTIGA SÄKERHETSFÖRESKRIFTER



FARA

Denna UPS-enhet innehåller LIVSFARLIG SPÄNNING. ENDAST AUKTORISERAD SERVICEPERSONAL får utföra reparationer eller service. Det finns inga delar som ANVÄNDAREN KAN UTFÖRA SERVICE PÅ inuti UPS-enheten.



VARNING

- Denna UPS-enhet har en egen energikälla (batterier). De utgående kontakterna kan vara strömförande när UPS-enheten inte är ansluten till en växelströmkälla.
- Ta aldrig bort nätsladden när UPS-enheten är påslagen. Detta tar bort skyddsjordningen från både UPS-enheten och den anslutna utrustningen.
- Minska risken för brand eller elektriska stötar genom att installera denna UPS-enhet inomhus, där temperatur och luftfuktighet är kontrollerade och där inga ledande föroreningar förekommer. Omgivande temperatur får ej överstiga 40°C. Använd inte utrustningen nära vatten eller vid hög luftfuktighet (max 95 %).
- För att överensstämma med internationell standard och installationsföreskrifter får inte den totala utrustning som anslutits till uttagen på denna UPS-enhet ha läcksström som överstiger 1,5 milliampere.
- Överströmsskydd för de utgående växelströmskretsarna ska tillhandahållas av andra för UPS-system med fasta utgångar.
- Bortkopplingsswitchar med passande dimensionering för de utgående växelströmskretsarna ska tillhandahållas av andra för UPS-system med fasta utgångar.



VIKTIGT

- Batterierna kan ge elektriska stötar eller brännskador från hög kortslutningsström. Följ tillämpliga anvisningar.
- Batterierna måste avyttras enligt anvisningarna i lokal lagstiftning.
- Använda batterier får aldrig brännas upp. De kan explodera.

Chapter 3 Installation

This section explains:

- Equipment inspection
- UPS internal battery connection
- UPS setup and installation
- Extended Battery Module (EBM) installation
- Remote emergency power-off (REPO) installation
- UPS rear panels

Inspecting the Equipment

If any equipment has been damaged during shipment, keep the shipping cartons and packing materials for the carrier or place of purchase and file a claim for shipping damage. If you discover damage after acceptance, file a claim for concealed damage.

To file a claim for shipping damage or concealed damage: 1) File with the carrier within 15 days of receipt of the equipment; 2) Send a copy of the damage claim within 15 days to your service representative.



NOTE Check the battery recharge date on the shipping carton label. If the date has expired and the batteries were never recharged, do not use the UPS. Contact your service representative.

Connecting the UPS Internal Battery

To ensure proper battery operation before installing the UPS:

1. Verify that the UPS is off and unplugged.
2. Remove the UPS front cover by pulling on both ends (see Figure 2).

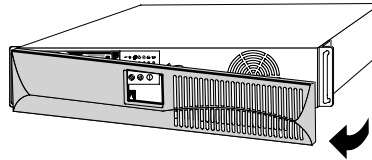

Figure 2. Removing the UPS Front Cover

3. Connect the internal battery connector (see Figure 3).

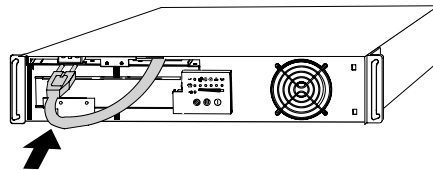

Figure 3. Connecting the Internal Battery Connector

4. Replace the UPS front cover (see Figure 4).

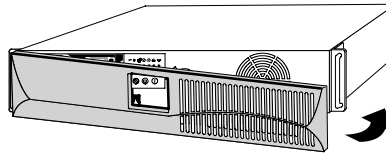

Figure 4. Replacing the UPS Front Cover

5. Continue to the following section, "UPS Setup."

UPS Setup

The Powerware 9125 UPS is designed for flexible configurations and can be installed in a rack or as a standalone cabinet.

If you are installing the UPS in a rack, continue to the following section "Rack-Mount Setup;" otherwise, continue to "Tower Setup" on page 18.

Rack-Mount Setup

The UPS can be installed in 19-inch racks and needs only 2U of valuable rack space.

CAUTION



The UPS and EBM are heavy (see page 61). A minimum of two people are required to lift the cabinets into the rack.



NOTE Mounting rails are required for each UPS and EBM cabinet. If rails are not already installed in your rack, contact your local distributor to order rail kits.

To install the UPS and optional EBMs in a rack:

1. Place the UPS on a flat, stable surface with the front of the UPS facing toward you.
2. Attach the supplied mounting handles to the mounting brackets and secure with the supplied screws (see Figure 5).
3. Align the mounting brackets with the screw holes on the side of the UPS and secure with the supplied screws (see Figure 5).
4. If installing optional EBMs, repeat Steps 1 through 3 for each cabinet.

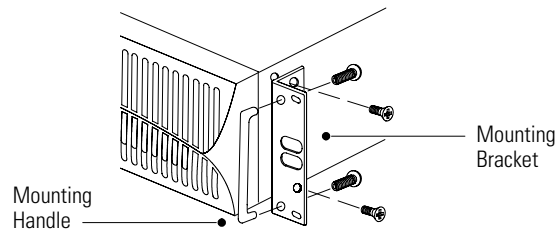

Figure 5. Installing the Mounting Handles and Brackets



NOTE The EBMs must be installed below the UPS as shown in Figure 6.

5. Slide the UPS and any optional EBMs into the rack.
6. Secure the cabinets to the rack according to the rail kit instructions.

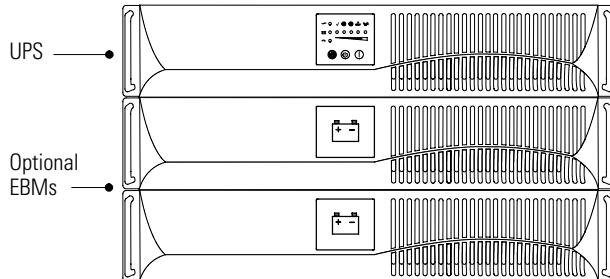

Figure 6. Rack-Mount UPS with EBMs

7. If installing optional EBMs, continue to “Extended Battery Module Installation” on page 22. Otherwise, continue to “Plug-Receptacle UPS Installation” on page 25 or “Hardwired UPS Installation” on page 27 to complete the installation.

Tower Setup

The setup varies depending on the number of cabinets you are installing:

1. **For one cabinet**, the pedestals must be installed. Continue to Step 2.

For two cabinets, the pedestals and the joining brackets must be installed. Skip to Step 6.

For three or more cabinets, the joining brackets must be installed. Skip to Step 9.
2. Place the UPS cabinet horizontally so that the left end of the cabinet is accessible (see Figure 7).
3. Align the pedestals with the screw holes on the end of the UPS cabinet. Secure the pedestals with the screws provided in the accessory kit.

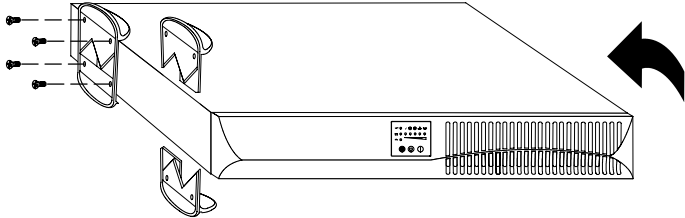

Figure 7. Installing UPS Pedestals (for One Cabinet)

- 4. Carefully position the cabinet upright with the air vents at the top (see Figure 8).
- 5. Continue to “Plug-Receiptacle UPS Installation” on page 25 or “Hardwired UPS Installation” on page 27 to complete the installation.

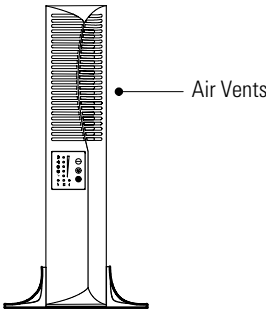

Figure 8. Pedestals with One Cabinet

- 6. Place the UPS cabinet horizontally so that the left end of the cabinet is accessible (see Figure 9).

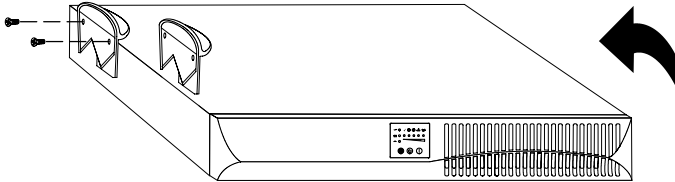

Figure 9. Installing UPS Pedestals (for Two Cabinets)

7. Place the EBM cabinet upside down so that the right end of the cabinet is accessible (see Figure 10).

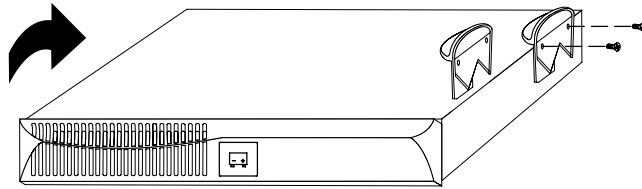

Figure 10. Installing EBM Pedestals

8. Align the pedestals with the screw holes on the end of the EBM cabinet. Secure the pedestals with the screws provided in the accessory kit.
9. Carefully position the cabinets upright with the air vents at the top (see Figure 11 or Figure 12).

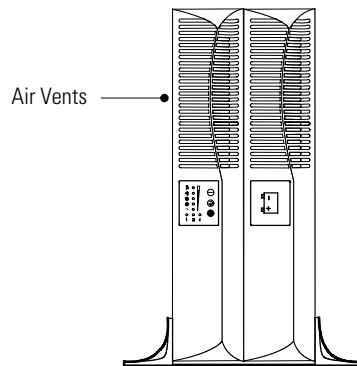

Figure 11. Pedestals with Two Cabinets



NOTE Pedestals are required for installations with one or two cabinets. Joining brackets are required for installations with two or more cabinets.

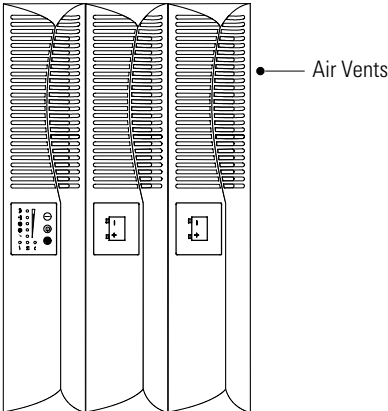

Figure 12. Tower Setup with Three Cabinets

- 10. Align each joining bracket with the adjacent corner screw holes and secure with the supplied screws (see Figure 13).

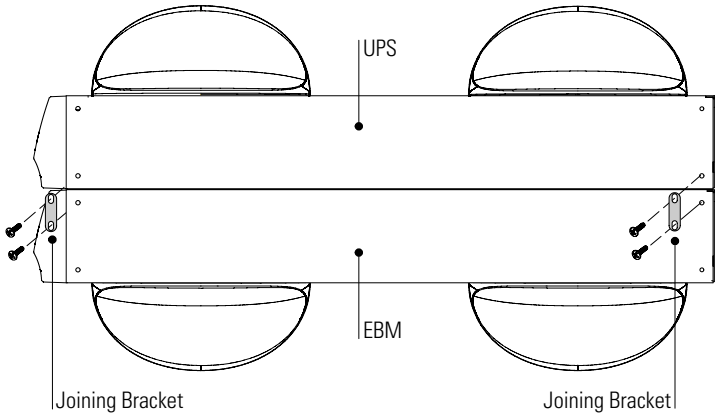

Figure 13. Installing the Joining Brackets (Top View with Pedestals)

- 11. If installing additional EBMs, repeat Step 10 for each cabinet.
- 12. If installing optional EBMs, continue to the following section, "Extended Battery Module Installation." Otherwise, continue to "Plug-Receptacle UPS Installation" on page 25 or "Hardwired UPS Installation" on page 27 to complete the installation.

Extended Battery Module Installation



CAUTION

A small amount of arcing may occur when connecting an EBM to the UPS. This is normal and will not harm personnel. Insert the EBM cable into the UPS battery connector quickly and firmly.

To install the optional EBMs:

1. If installing an EBM with an E/EH UPS model, skip to Step 4; otherwise, continue to Step 2.
2. Plug the EBM cable(s) into the battery connector(s) as shown in Figure 14. Up to four EBMs may be connected to the UPS.
3. Continue to “Plug-Receptacle UPS Installation” on page 25 or “Hardwired UPS Installation” on page 27.

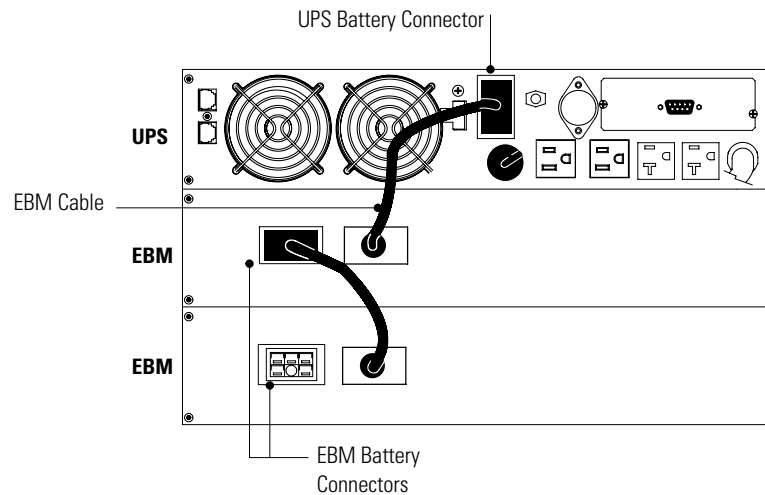

Figure 14. Typical EBM Installation (120V UPS Model Shown)

- 4. E/EH UPS models have a battery connector cover that must be removed before installing the EBM(s). Remove the cover from the rear panel as shown in Figure 15.



NOTE Keep the battery connector cover and screws for future use. If the UPS is stored or used without an EBM, the battery connector cover must be installed as a safety precaution.

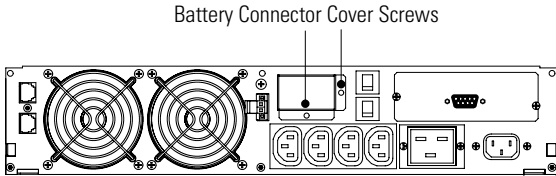

Figure 15. Battery Connector Cover (E/EH UPS Models Only)

- 5. Remove the cover from the EBM cable as shown in Figure 16.



NOTE Keep the EBM cable cover and screws for future use. If the EBM is stored or removed from the UPS, the EBM cable cover must be installed as a safety precaution.

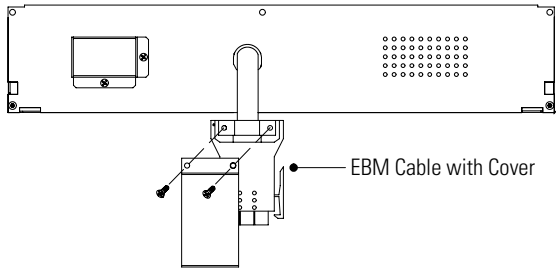

Figure 16. EBM Cable Cover (E/EH UPS Models Only)

6. Plug the EBM cable into the UPS battery connector (see Figure 17).
7. Attach the fixed cover plate (supplied in the accessory kit) to the EBM cable as shown in Figure 17.

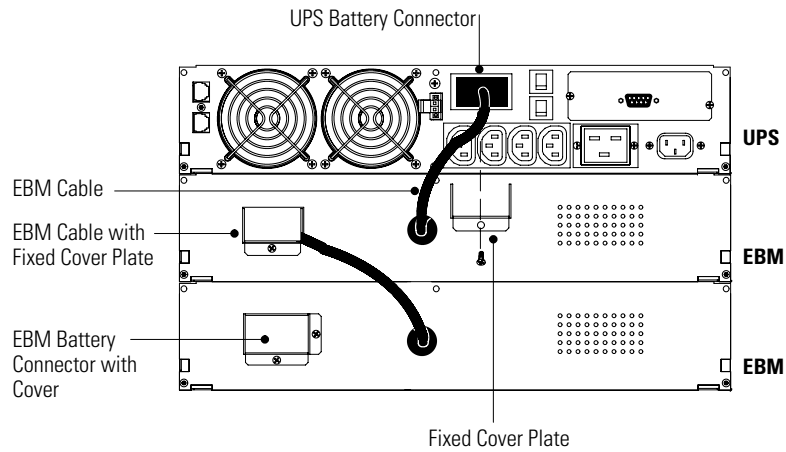

Figure 17. EBM Installation for E/EH UPS Models Only

8. If additional EBMs are to be installed, remove the EBM battery connector cover. Remove the cover from the EBM cable of the second cabinet and plug the EBM cable into the battery connector on the first EBM. Attach the fixed cover plate to the EBM cable.

Repeat for each additional EBM. Up to four EBMs may be connected to the UPS.

9. Continue to the following section, "Plug-Receptacle UPS Installation" or "Hardwired UPS Installation" on page 27.

Plug-Receptacle UPS Installation



NOTE Do not make unauthorized changes to the UPS or accessories; otherwise, damage may occur to your equipment and void your warranty.

Figure 18 shows a typical installation only. See “UPS Rear Panels” on page 33 for the rear panel of each model.

To install a plug-receptacle UPS:

1. If you are installing power management software, connect your computer to the UPS communication port using the supplied communication cable.

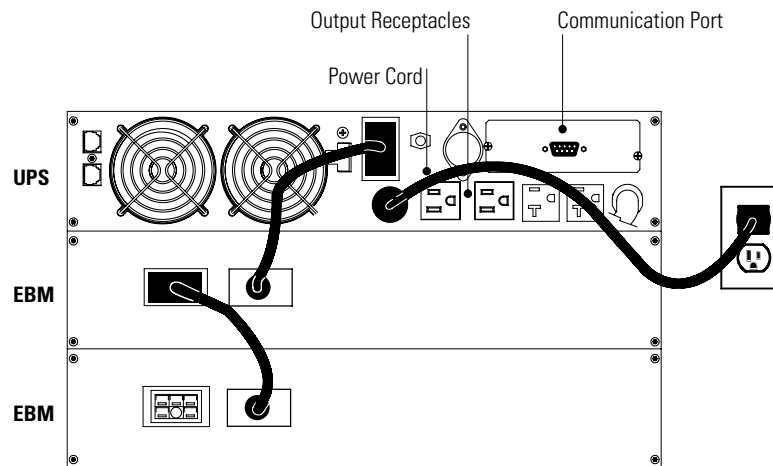

Figure 18. Typical Installation (120V UPS Model Shown)



2. Plug the equipment to be protected into the appropriate UPS output receptacles (see page 50 for more information on load segments).



NOTE DO NOT protect laser printers with the UPS because of the exceptionally high power requirements of the heating elements.

3. If an emergency power-off (disconnect) switch is required by local codes, see “Remote Emergency Power-off Installation” on page 31 to install the REPO switch before powering on the UPS.

4. **For 208/230V models only.** Plug the detachable UPS power cord into the input connector on the UPS rear panel.
5. Plug the UPS power cord into a power outlet.

All front panel indicators flash briefly and the UPS conducts a self-test. When the self-test is complete, the ~ indicator flashes, indicating the UPS is in Standby mode with the equipment offline. If the  or  indicator flashes, see page 65.

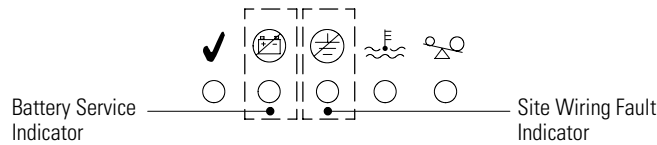

Figure 19. Fault Indicators

6. Press the On | button.

The ~ indicator illuminates solid and the bar graph indicators display the percentage of load being applied to the UPS. The UPS is now in Normal mode and supplying power to your equipment.

To change the factory-set defaults, see “Configuration” on page 41.



NOTE *The batteries charge to 90% capacity in approximately 3 hours. However, it is recommended that the batteries charge for 24 hours after installation or long-term storage.*

Hardwired UPS Installation



WARNING

Only qualified service personnel (such as a licensed electrician) shall perform the electrical installation. Risk of electrical shock.



CAUTION

- For UPS models with hardwired outputs, overcurrent protection for the output AC circuit(s) is to be provided by others.
 - For UPS models with hardwired outputs, suitably rated disconnect switches for the output AC circuit(s) are to be provided by others.
-



NOTE Do not make unauthorized changes to the UPS or accessories; otherwise, damage may occur to your equipment and void your warranty.

The Powerware 9125 hardwired models require a dedicated branch circuit that meets the following requirements:

- 16A, 2-pole circuit breaker for EH and GH models/20A, 2-pole circuit breaker for EUH models to provide short circuit and overcurrent protection
- The protection device requires a two-pole disconnection device between the UPS output and the load
- The breaker must be wall-mounted and readily accessible to the operator
- For Europe, the breaker must be approved by the appropriate safety agency (such as TÜV or VDE) and have a contact air gap of at least 3 mm
- 200–240 Vac
- Single-phase
- 50/60 Hz
- Flexible metal conduit (recommended for ease of service and maintenance)

To hardwire the UPS:

1. If you are installing power management software, connect your computer to the UPS communication port using the supplied communication cable.
2. Switch off utility power at the distribution point where the UPS will be connected. Be absolutely sure there is no power.

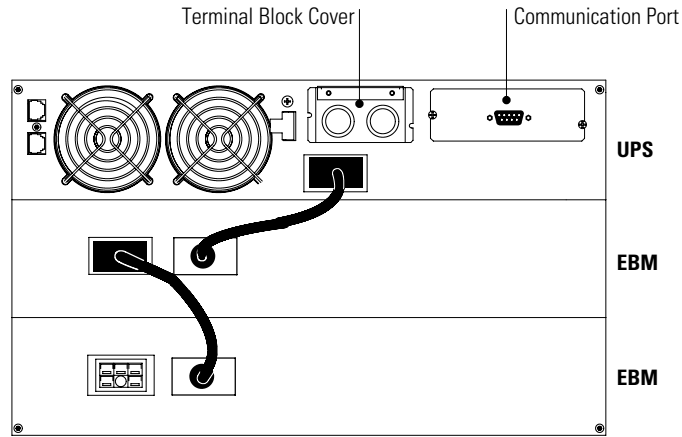

Figure 20. Typical Hardwired UPS Installation

3. Remove the terminal block cover and the wiring knockouts (see Figure 21). Retain the terminal block cover and screws.

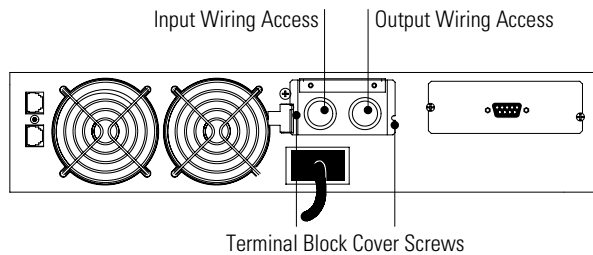

Figure 21. Wiring Access and Terminal Block

4. Pull the input and output wires through separate conduit, leaving approximately 0.5m (2 ft) of exposed wire. Attach a flexible metal fitting to the end of each conduit.

- 5. Insert each conduit through a wiring access entry and attach the conduit fitting to the panel. Strip 1.5 cm (0.5") of insulation from the end of each incoming wire.
- 6. Connect the input and ground wires to the input terminal block according to Figure 22 and Table 1.
- 7. Connect the output and ground wires to the output terminal block according to Figure 22 and Table 1.

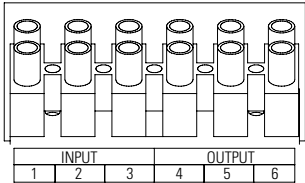

Figure 22. Terminal Block



Table 1. UPS Wiring Specifications

Wire Function	Terminal Position	UPS Wire Function		Terminal Wire Size Rating*	Tightening Torque
		EUH Models	EH and GH Models		
Input	1	L2	N	2–10 mm ² (14–8 AWG)	4.38 Nm (35 lb in)
	2	G	G		
	3	L1	L		
Output	4	L2	N	2–10 mm ² (14–8 AWG)	4.38 Nm (35 lb in)
	5	G	G		
	6	L1	L		

* Use 2.0 mm² (14 AWG) 75°C copper wire minimum.

- 8. Reinstall the terminal block cover.
- 9. If an emergency power-off (disconnect) switch is required by local codes, see “Remote Emergency Power-off Installation” on page 31 to install the REPO switch before powering on the UPS.

10. Switch the main utility breaker on.

All front panel indicators flash briefly and the UPS conducts a self-test. When the self-test is complete, the ~ indicator flashes, indicating the UPS is in Standby mode with the equipment offline. If the  or  indicator flashes, see page 65.

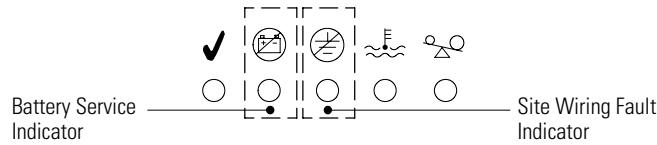

Figure 23. Fault Indicators

11. Press the On | button.

The ~ indicator illuminates solid and the bar graph indicators display the percentage of load being applied to the UPS. The UPS is now in Normal mode and supplying power to your equipment.

To change the factory-set defaults, see “Configuration” on page 41.





NOTE The batteries charge to 90% capacity in approximately 3 hours. However, it is recommended that the batteries charge for 24 hours after installation or long-term storage.

Remote Emergency Power-off Installation

The Powerware 9125 includes a REPO port that allows power to be switched off at the UPS output from a customer-supplied switch in a remote location.

The REPO feature shuts down the protected equipment immediately and does not follow the orderly shutdown procedure initiated by any power management software.

Any devices that are operating on battery power are also shut down immediately. When the REPO switch is reset, the equipment will not return to battery power until the UPS is manually restarted.

If the Off  button is pressed after the REPO is activated, the UPS remains in Standby mode when restarted until the On  button is pressed.

WARNING



The REPO circuit is an IEC 60950 safety extra low voltage (SELV) circuit. This circuit must be separated from any hazardous voltage circuits by reinforced insulation.

CAUTION



To ensure the UPS stops supplying power to the load during any mode of operation, the input power must be disconnected from the UPS when the emergency power-off function is activated.



NOTE *The REPO function activates when the REPO contacts open.*

NOTE *If the REPO function is not needed, the REPO connector must remain installed in the REPO port on the UPS rear panel.*

NOTE *For Europe, the emergency switch requirements are detailed in Harmonized document HD-384-48 S1, "Electrical Installation of the Buildings, Part 4: Protection for Safety, Chapter 46: Isolation and Switching."*

To install the REPO switch:

1. Verify that the UPS is off and disconnected from utility power.
2. Remove the REPO connector from the REPO port on the UPS rear panel.

3. Connect isolated, normally-closed, dry contacts (rated to handle 60 Vdc maximum, 30 Vac RMS maximum, and 20 mA maximum) across the REPO device to Pin 1 and Pin 2 (see Figure 24). Use stranded, non-shielded wiring, size 0.75 mm²–0.5 mm² (18–20 AWG).



NOTE A separate contact must simultaneously cause UPS input AC power to be removed.

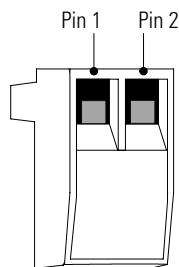

Figure 24. REPO Connector

4. Reconnect the REPO connector to the REPO port.
5. Verify that the externally-connected REPO switch is not activated to enable power to the UPS output.
6. Plug in the UPS (or switch the main utility breaker on for hardwired units) and start the UPS by pressing the On | button.
7. Activate the external REPO switch to test the REPO function.
8. De-activate the external REPO switch and restart the UPS.

UPS Rear Panels

This section shows the rear panels of the Powerware 9125 models.

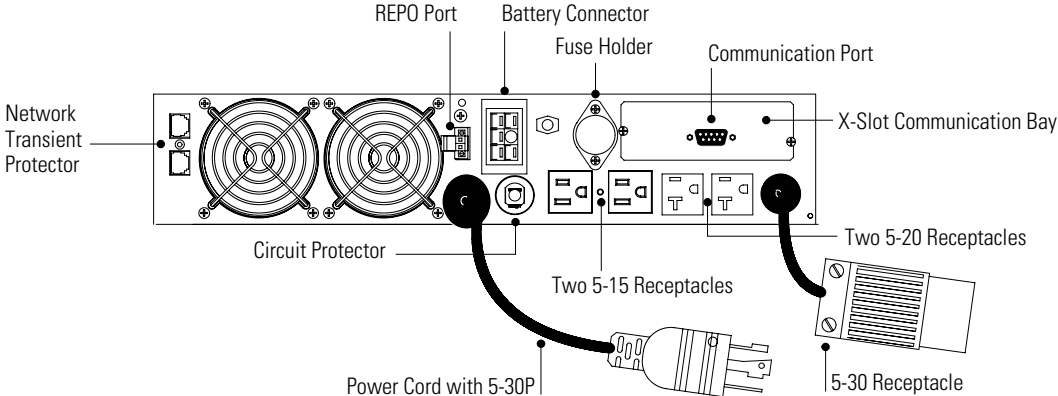

Figure 25. 2500/3000 VA, 120V Rear Panel

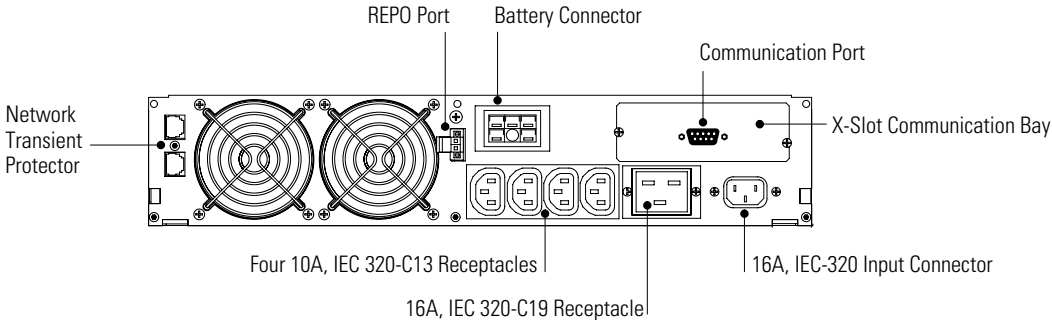

Figure 26. 2500/3000 VA, 208V Rear Panel

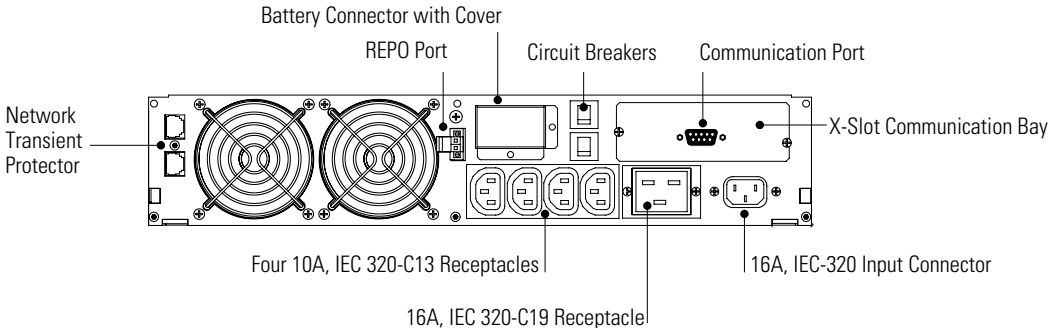

Figure 27. 2500/3000 VA, 230V Rear Panel

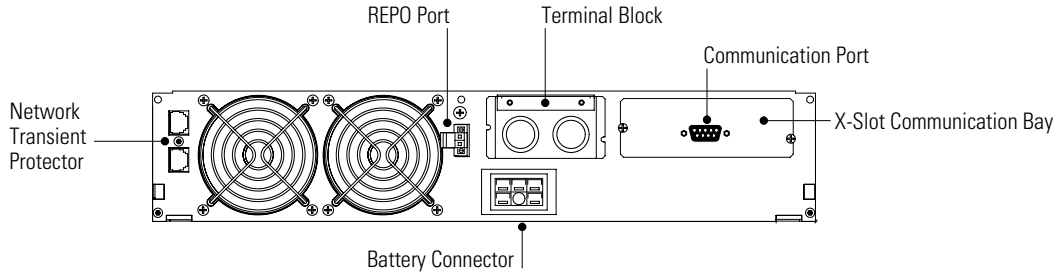

Figure 28. 2500/3000 VA, 208–240V Hardwired Rear Panel

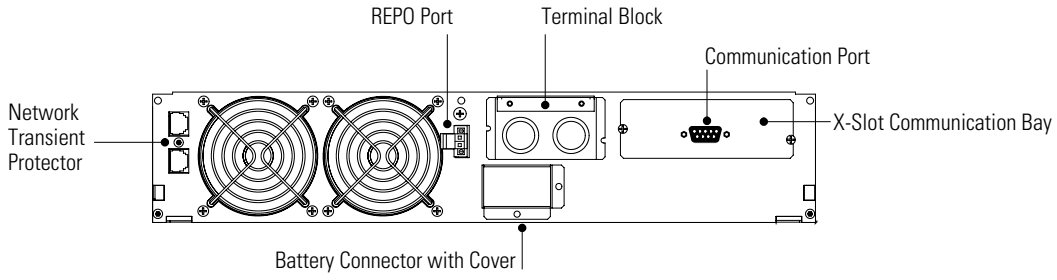

Figure 29. 2500/3000 VA, 230V Hardwired Rear Panel

Chapter 4 Operation

This section describes:

- Turning the UPS on and off
- Starting the UPS on battery
- Initiating the self-test
- Operating modes

Turning the UPS On

After the UPS is connected to utility power, it conducts a self-test and enters Standby mode.

To turn on the UPS, press the On | button on the front panel. The  indicator illuminates solid and the bar graph indicators display the percentage of load being applied to the UPS.

Starting the UPS on Battery

To turn on the UPS without using utility power, press and hold the On | button for at least four seconds. The UPS starts up in Battery mode and supplies battery power to your equipment. When the UPS starts on battery, it does not conduct a self-test to conserve battery power.

Turning the UPS Off



NOTE Pressing the Off  button while the UPS is in Battery mode causes the UPS to shut down immediately.

To turn off the UPS:

1. Prepare your equipment for shutdown.
2. Press and hold the Off  button for approximately three seconds. The UPS transfers to Standby mode (if utility power is available) and removes power from your equipment.
3. Unplug or remove utility power from the UPS; the UPS shuts down in five seconds. All front panel indicators flash briefly prior to shutdown.

If you do not unplug or remove utility power from the UPS, it remains in Standby mode.

Initiating the Self-Test



NOTE The batteries must be fully charged and the UPS must not be in Battery mode to perform the self-test.

NOTE AC input power must be applied to the UPS for 24 hours before performing the self-test.

Press and hold the  button for three seconds to initiate the self-test. During the five-second test, the bar graph indicators cycle through twice. If the alarm beeps or a UPS alarm indicator stays on, see Table 11 on page 64.

Operating Modes

Powerware 9125's front panel indicates the UPS status through the UPS indicators. Figure 30 shows the UPS front panel indicators and controls.

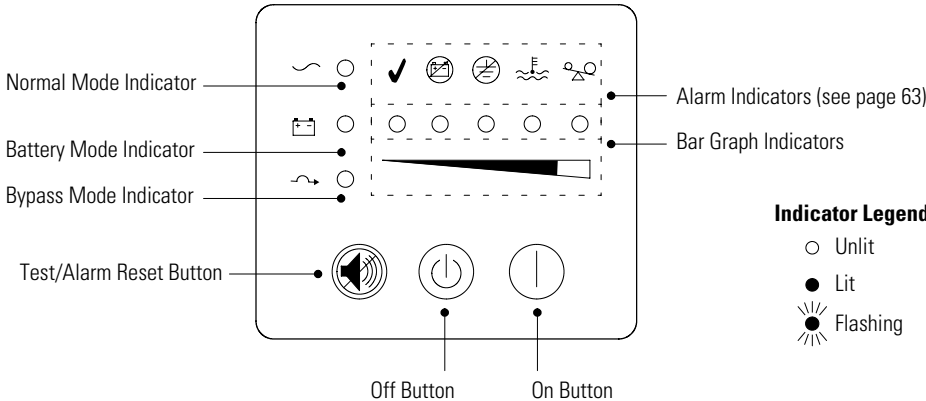

Figure 30. UPS Front Panel

Normal Mode

During Normal mode, the \sim indicator illuminates and the front panel displays the percentage of UPS load capacity being used by the protected equipment (see Figure 31). The UPS monitors and charges the batteries as needed and provides power protection to your equipment.

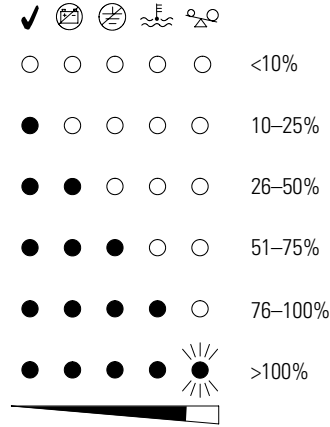



Figure 31. Load Level Indicators

When all of the bar graph indicators are illuminated and the \sim indicator flashes, power requirements exceed UPS capacity; see page 65 for more information.

Battery Mode

When the UPS is operating during a power outage, the alarm beeps once per second and the  indicator illuminates. The front panel displays the approximate percentage of battery capacity remaining (see Figure 32).

When utility power returns, the UPS transfers to Normal mode operation while the battery recharges.

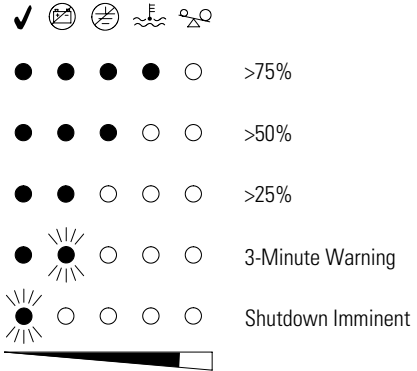



Figure 32. Battery Capacity Indicators

If battery capacity becomes low while in Battery mode, the  indicator starts flashing and the alarm becomes continuous, indicating approximately three minutes of battery time remaining. When shutdown is imminent, the  indicator flashes.



NOTE Depending on the UPS load, the 3-minute warning may occur before the batteries reach 25% capacity; the front panel immediately displays the 3-minute warning. For UPS and Extended Battery Module (EBM) runtimes, see Table 10 on page 62.

These warnings are approximate, and the actual time to shutdown may vary significantly. Once these warnings are indicated, immediately complete and save your work to prevent data loss and similar difficulties.

When utility power is restored after the UPS shuts down, the UPS automatically restarts.

Bypass Mode

In the event of a UPS overload or internal failure, the UPS transfers your equipment to utility power. Battery mode is not available; however, the utility power continues to be passively filtered by the UPS. The  indicator illuminates. The UPS transfers to Bypass mode when:

- The UPS has an overtemperature condition.
- The UPS has an overload condition of 101 to 150% for 30 seconds.
- The UPS detects a fault in the battery or UPS electronics.

Standby Mode

When the UPS is turned off and remains connected to utility power, the UPS is in Standby mode. The  indicator flashes and the bar graph indicators are off, indicating that power is not available to your equipment. The battery recharges when necessary.



NOTE For 220–240V models, the output receptacles may remain electrically live (up to 110–120V). Unplug the UPS to ensure power is not available to the output receptacles.

Chapter 5 Configuration

When the UPS is in Configuration mode, the bar graph indicators represent the configuration options. Use the control buttons (On | button and  button) to modify the UPS configuration. Figure 33 shows the LEDs and Table 2 explains the corresponding options.



NOTE *The UPS can be configured while in Battery mode. If the UPS transfers to battery power while in Configuration mode, the UPS remains in Configuration mode and indicates Battery mode on the front panel after exiting Configuration mode.*

To reconfigure the UPS default settings:

1. Press and hold the On | button and the  button simultaneously for one beep. The UPS transfers to Configuration mode.

The LEDs flash briefly and then display the enabled options.

2. Press the On | button to scroll through the options. Each time you press the button, the UPS beeps. The LED for the selected option indicates the current setting; flashing represents disabled options (see Figure 33 and Table 2).

Scrolling past the last LED returns to the first configuration option.

If you press the On | button and nothing happens, the UPS is still in Operation mode. Repeat Step 1 to enter Configuration mode, and then perform Step 2.

3. Press the  button for approximately one second to select the Voltage option or to toggle the Site Wiring Fault Alarm or AC Input Failure Alarm on or off.



NOTE *The UPS exits Configuration mode automatically after two minutes of inactivity.*

4. Press and hold the On | button and the  button simultaneously to exit Configuration mode at any time.

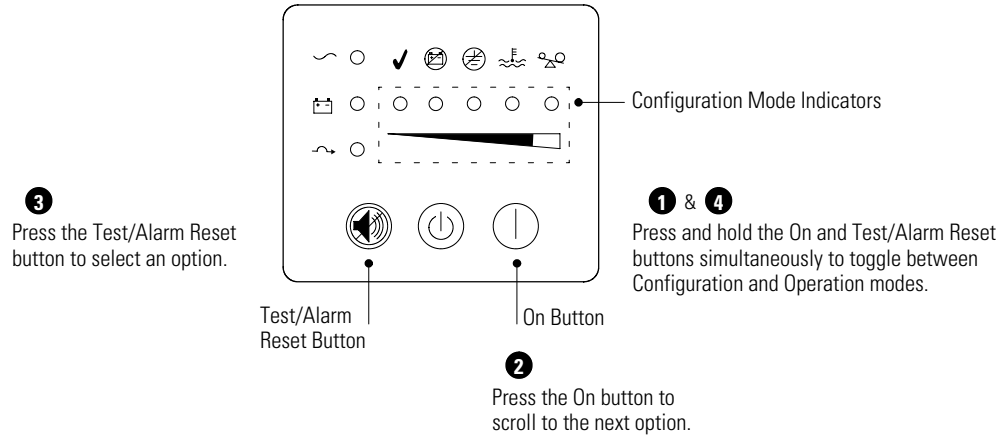
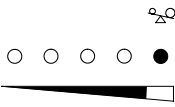
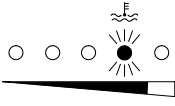
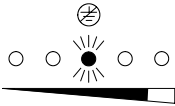
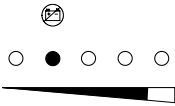
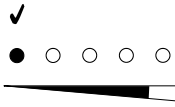

Figure 33. Using Configuration Mode

Table 2. Configuration Mode LEDs and Options

Configuration Mode LEDs	Option	LED Status	Explanation
	120, 208, or 230V Nominal Input Voltage	On (default)	Nominal input voltage is one of the following: <ul style="list-style-type: none"> • 120V for U models • 208V for EU/EUH and G/GH models • 230V for E/EH models All other nominal input voltages are disabled.
		Flashing	Disabled; one of the other input voltage options is selected.
	110, 220, or 230V Nominal Input Voltage	On	Selecting this option changes the nominal input voltage to one of the following: <ul style="list-style-type: none"> • 110V for U models • 220V for E/EH models • 230V for EU/EUH and G/GH models
		Flashing	Disabled; one of the other input voltage options is selected.
	127 or 240V Nominal Input Voltage	On	Selecting this option changes the nominal input voltage to one of the following: <ul style="list-style-type: none"> • 127V for U models • 240V for EU/EUH, E/EH, and G/GH models
		Flashing	Disabled; one of the other input voltage options is selected.
	Site Wiring Fault Alarm	On (default)	Alarm sounds when the polarity of the outlet is reversed or the ground connection is missing; have a qualified electrician repair the outlet wiring.
		Flashing*	Alarm DOES NOT sound when the polarity of the outlet is reversed or the ground connection is missing. * For 208V or 230V models, flashing is the default; contact your service representative to activate this alarm.
	AC Input Failure Alarm	On (default)	Alarm sounds when there is an AC input failure.
		Flashing	Alarm DOES NOT sound when there is an AC input failure.

Chapter 6 Additional UPS Features

This section describes:

- X-Slot cards
- Network transient protector
- Load segments

X-Slot Cards

X-Slot cards allow the UPS to communicate in a variety of networking environments and with different types of devices. The Powerware 9125 is factory-installed with a Single-Port Card, which can be replaced with one of the following X-Slot cards:

- ConnectUPS™-X Web/SNMP Card - has SNMP and HTTP capabilities as well as monitoring through a Web browser interface; connects to a twisted-pair Ethernet (10/100BaseT) network. It has a built-in switching hub that allows three additional network devices to be connected to the network without the requirement of additional network drops. In addition, a Powerware Environmental Monitoring Probe can be attached to obtain humidity, temperature, smoke alarm, and security information.
- Relay Interface Card - has isolated dry contact (Form-C) relay outputs for UPS status: Utility failure, Low battery, UPS alarm/OK, or On bypass.
- Modbus® Card - allows you to continuously and reliably monitor the UPSs in your Building Management System (BMS).
- Multi-Server Card - has six serial communication ports that can communicate simultaneously with other computers using Powerware LanSafe® Power Management Software (provided on the Software Suite CD).
- USB Card - connects to a USB port on your computer.

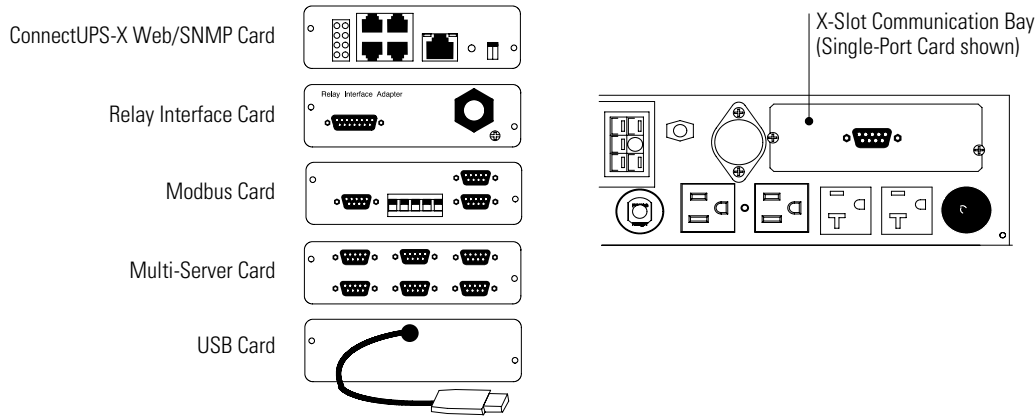

Figure 34. Optional X-Slot Cards

Single-Port Card

The Powerware 9125 is factory-installed with a Single-Port Card, enabling connection to a PC for power management control or to the Powerware Expansion Chassis for multiple communication options.

To establish communication between the UPS and a computer, connect your computer to the UPS communication port using the supplied communication cable.

When the communication cable is installed, power management software can exchange data with the UPS. The software polls the UPS for detailed information on the status of the power environment. If a power emergency occurs, the software initiates the saving of all data and an orderly shutdown of the equipment.

The cable pins are identified in Figure 35 and the pin functions are described in Table 3.

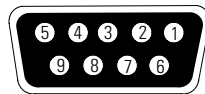

Figure 35. Communication Port

Table 3. Communication Port Pin Assignment

Pin Number	Signal Name	Function	Direction from the UPS
1	Low Batt	Low Battery relay contact; 20 mA, 30 Vdc contact rating	Out
2	TxD	Transmit to external device	Out
3	RxD	Receive from external device	In
4	DTR	PnP (Plug and Play) from external device (tied to Pin 6)	In
5	GND	Signal common (tied to chassis)	—
6	DSR	To external device (tied to Pin 4)	Out
7	RTS	PnP from external device (default) or On Bypass relay contact (jumper-selectable)	In / Out
8	AC Fail	AC Fail relay contact; 20 mA, 30 Vdc contact rating	Out
9	Power Source	+V (8 to 24 volts DC power)	Out

The On-Bypass Relay Contact. You can enable the On-Bypass relay using the jumper on the Single-Port Card. The jumper default is disabled.

To enable the On-Bypass relay:

1. Remove the Single-Port Card on the UPS rear panel. Retain the screws (see Figure 36).

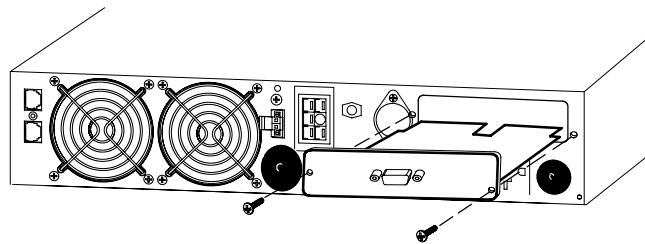

Figure 36. Removing the Single-Port Card

2. Move the J3 jumper to the AS/400® position to enable the On-Bypass relay, as shown in Figure 37.

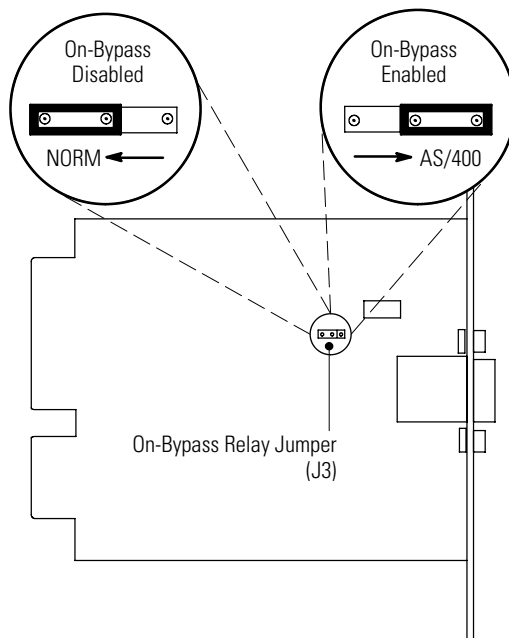

Figure 37. On-Bypass Relay Jumper

3. To prevent electrostatic discharge (ESD), place one hand on a metal surface such as the UPS rear panel.

Align the Single-Port Card with the slot guides and slide the card into the slot until it is firmly seated.

4. Secure the Single-Port Card with the screws removed in Step 1.

Network Transient Protector

The network transient protector, shown in Figure 38, is located on the rear panel and has jacks labeled IN and OUT. This feature accommodates a single RJ-45 (10BaseT) network connector.

Low voltage models can also accommodate an RJ-11 telephone connector that provides protection for modems, fax machines, or other telecommunications equipment. As with most modem equipment, it is not advisable to use this jack in digital PBX (Private Branch Exchange) environments.



NOTE *DO NOT connect any telephone or fax/modem equipment to the 230V models; only network protection is available for 230V models.*

1. Connect the input connector of the equipment you are protecting to the jack labeled IN.
2. Connect the network or telephone cable (low voltage models only) to the jack labeled OUT.



Figure 38. Network Transient Protector

Load Segments

Load segments are sets of receptacles that can be controlled by power management software, providing an orderly shutdown and startup of your equipment. For example, during a power outage, you can keep key pieces of equipment running while you turn off other equipment. This feature allows you to save battery power. See your power management software manual for details (refer to the Software Suite CD or www.powerware.com for the latest information).



NOTE If power management software is not used, the individual load segments cannot be controlled.

For hardwired UPSs, there is only one load segment. The terminal block serves as Load Segment 1.

Each plug-receptacle UPS has two load segments as shown in Figure 39 and Figure 40.

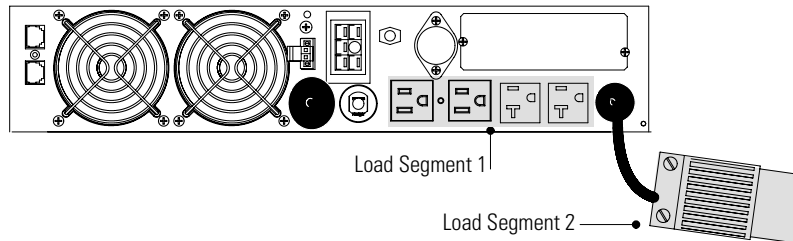

Figure 39. UPS Load Segments for 120V Models

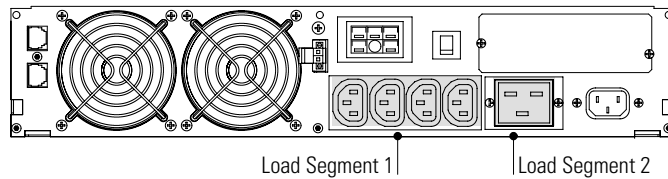

Figure 40. UPS Load Segments for 208/230V Models

Chapter 7 UPS Maintenance

This section explains how to:

- Care for the UPS and batteries
- Replace the batteries
- Test new batteries
- Recycle used batteries or UPS

UPS and Battery Care

For the best preventive maintenance, keep the area around the UPS clean and dust-free. If the atmosphere is very dusty, clean the outside of the system with a vacuum cleaner.

For full battery life, keep the UPS at an ambient temperature of 25°C (77°F).



NOTE *If the UPS requires any type of transportation, verify that the UPS is unplugged and turned off and then disconnect the UPS internal battery connector using the steps in “Connecting the UPS Internal Battery” on page 16 in reverse order.*





NOTE *The batteries in the UPS are rated for a 3–5 year service life. The length of service life varies, depending on the frequency of usage and ambient temperature. Batteries used beyond expected service life will often have severely reduced runtimes. Replace batteries at least every 5 years to keep units running at peak efficiency.*

Storing the UPS and Batteries

If you store the UPS for a long period, recharge the batteries every 12 months by plugging the UPS into a power outlet. The batteries charge to 90% capacity in approximately 3 hours. However, it is recommended that the batteries charge for 24 hours after long-term storage.

Check the battery recharge date on the shipping carton label. If the date has expired and the batteries were never recharged, do not use the UPS. Contact your service representative.

When to Replace Batteries

When the  indicator flashes, the batteries may need replacing. Conduct a self-test by pressing and holding the  button for three seconds. After the five-second test is complete, the  indicator should turn off (it may take a few seconds to turn off). If the  indicator continues flashing, contact your service representative to order new batteries.

Replacing Batteries



NOTE *DO NOT DISCONNECT the batteries while the UPS is in Battery mode.*

With the hot-swappable battery feature, UPS batteries can be replaced easily without turning the UPS off or disconnecting the load.

If you prefer to remove input power to change the batteries, see “Turning the UPS Off” on page 36.

Consider all warnings, cautions, and notes before replacing batteries.

WARNING



- Batteries can present a risk of electrical shock or burn from high short-circuit current. The following precautions should be observed: 1) Remove watches, rings, or other metal objects; 2) Use tools with insulated handles; 3) Do not lay tools or metal parts on top of batteries.
 - **ELECTRIC ENERGY HAZARD.** Do not attempt to alter any battery wiring or connectors. Attempting to alter wiring can cause injury.
-

How to Replace UPS Internal Batteries

CAUTION



Pull the battery out onto a flat, stable surface. The battery is unsupported when you pull it out of the UPS.

To replace the UPS internal batteries:

1. Remove the UPS front cover by pulling on both ends (see Figure 41).

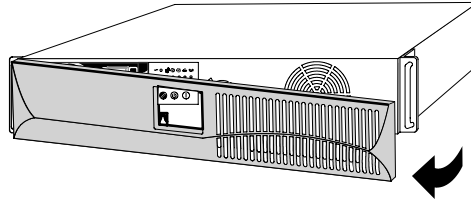

Figure 41. Removing the UPS Front Cover

2. Push down on and unsnap the LED panel (see Figure 42).
3. Disconnect the battery cable from the UPS and cut the battery cable wire tie.

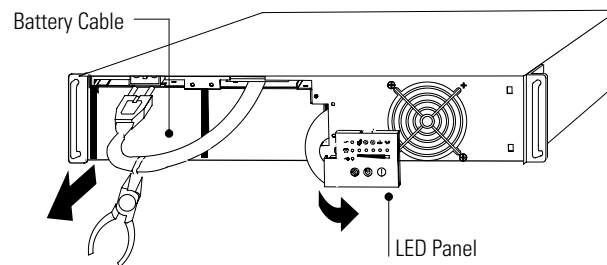

Figure 42. Disconnecting the Battery Cable

4. Unscrew and set aside the battery retaining bracket (see Figure 43).

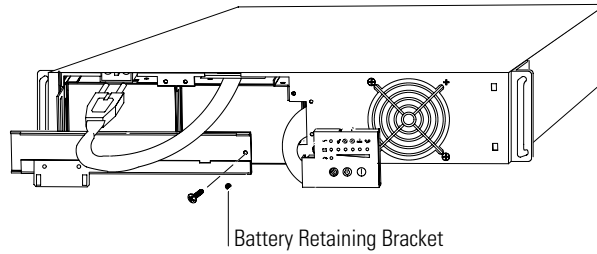

Figure 43. Removing the Battery Retaining Bracket

5. Pull the battery trays out onto a flat, stable surface (see Figure 44). See "Recycling the Used Battery or UPS" on page 57 for proper disposal.

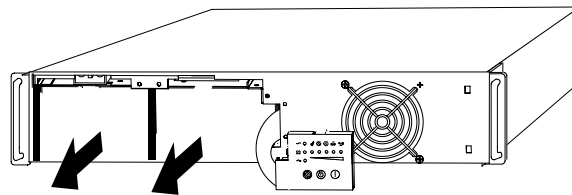

Figure 44. Removing the Battery Trays

6. Slide the new battery trays into the UPS.
The battery trays are keyed to prevent improper connection. The battery tray with the battery cable goes in the bay to the right.
7. Reinstall the battery retaining bracket removed in Step 4.
8. Reconnect the battery cable. Secure the cable to the battery retaining bracket with a tie wrap.
9. Snap the LED panel into place.
10. Replace the UPS front cover.

How to Replace Extended Battery Modules

CAUTION



The Extended Battery Module (EBM) is heavy (see page 61). A minimum of two people are required to lift the EBM when it is replaced.

To replace the Extended Battery Modules (EBMs):

1. Unplug the EBM cable from the UPS.



NOTE For 230V models, remove the fixed cover plate, and then unplug the EBM cable from the UPS.

If additional EBMs are installed, unplug the EBM cable from the battery connector on each EBM.

2. If the EBM is in a tower configuration, remove the joining brackets.
3. If the EBM has pedestals installed, remove the pedestals and retain.
4. If the EBM is in a rack, install the mounting handles and brackets on the new EBM.
5. Replace the EBM. See "Recycling the Used Battery or UPS" on page 57 for proper disposal.
6. Reinstall the pedestals if removed in Step 3.
7. Reinstall the joining brackets if removed in Step 2.
8. Plug the EBM cable(s) into the battery connectors as shown in Figure 45.

For E/EH UPS models, remove the cover from the EBM cable and plug the EBM cable into the UPS. Attach the fixed cover plate to the EBM cable.

9. For additional EBMs, plug the EBM cable into the battery connector on the adjacent EBM.

For E/EH UPS models, remove the EBM battery connector cover. Remove the cover from the EBM cable of the second cabinet and plug the EBM cable into the battery connector on the first EBM. Attach the fixed cover plate to the EBM cable.

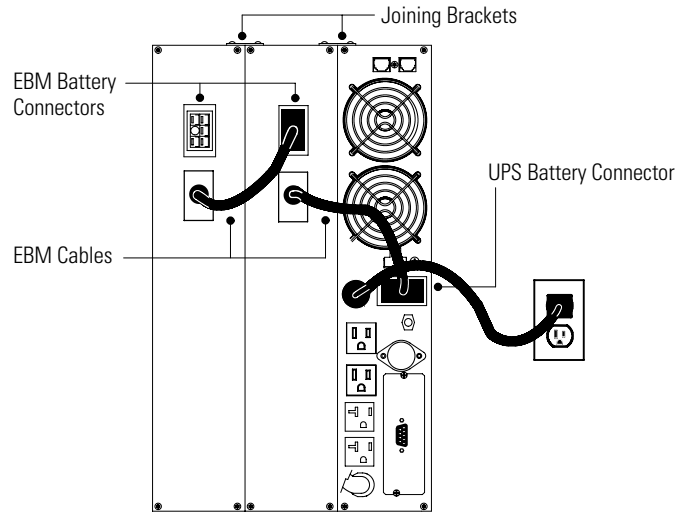





Figure 45. EBM Connections (120V UPS Model Shown)

Testing New Batteries

Press and hold the  button for three seconds to initiate a self-test. After the five-second test is complete, the  indicator should turn off (it may take a few seconds to turn off). If the  indicator stays on, check the battery connections. Call your service representative if the problem persists.

Recycling the Used Battery or UPS

Contact your local recycling or hazardous waste center for information on proper disposal of the used battery or UPS.



WARNING

- Do not dispose of the battery or batteries in a fire. Batteries may explode. Proper disposal of batteries is required. Refer to your local codes for disposal requirements.
- Do not open or mutilate the battery or batteries. Released electrolyte is harmful to the skin and eyes. It may be toxic.



CAUTION

Do not discard the UPS or the UPS batteries in the trash. This product contains sealed, lead-acid batteries and must be disposed of properly. For more information, contact your local recycling/reuse or hazardous waste center.



CAUTION

Do not discard waste electrical or electronic equipment (WEEE) in the trash. For proper disposal, contact your local recycling/reuse or hazardous waste center.

Chapter 8 Specifications

This section provides the following specifications:

- Model list
- Electrical input and output
- Weights and dimensions
- Environmental and safety
- Battery

Table 4. Model Specifications

Model Number	Power Levels (Rated at Nominal Inputs)	Nominal Voltage	Input Voltage Range
PW9125-2500U	2500 VA, 1750W	120V default; 110, 120, 127V selectable	80–144V
PW9125-3000U	3000 VA, 2100W		
PW9125-2500EU	2500 VA, 1750W	208V default; 230, 240V selectable	160–288V
PW9125-2500G			
PW9125-3000EU	3000 VA, 2100W	230V default; 220, 240V selectable	160–288V
PW9125-3000G			
PW9125-2500EUH	2500 VA, 1750W	208V default; 230, 240V selectable	160–288V
PW9125-2500GH			
PW9125-3000EUH	3000 VA, 2100W	230V default; 220, 240V selectable	160–288V
PW9125-3000GH			
PW9125-2500EH	2500 VA, 1750W	230V default; 220, 240V selectable	160–288V
PW9125-3000EH	3000 VA, 2100W		

Table 5. Power Connections

Model	Input Connection	Output Connections	
		Load Segment 1	Load Segment 2
PW9125-2500U PW9125-3000U	6-ft, 5-30P attached power cord	(2) 5-15R and (2) 5-20R	(1) 5-30R output cord
PW9125-2500EU PW9125-3000EU PW9125-2500E PW9125-3000E PW9125-2500G PW9125-3000G	16A, IEC 320-C20 input connector Country-specific, detachable power cord	(4) 10A, IEC 320-C13	(1) 16A, IEC 320-C19
PW9125-2500EUH PW9125-3000EUH PW9125-2500EH PW9125-3000EH PW9125-2500GH PW9125-3000GH	Terminal block	Terminal block	N/A

Table 6. Technical Specifications

Nominal Frequency	45–65 Hz, 50/60 Hz auto-sensing
Noise Filtering	MOVs and line filter for normal and common mode noise
Regulation (Normal Mode)	Nominal output voltage $\pm 3\%$
Regulation (Battery Mode)	Nominal output voltage $\pm 3\%$
Voltage Waveform	Normal mode: Sine wave; <5% THD with full PFC and nonlinear load

Table 7. Weights and Dimensions

	UPS	Extended Battery Module
Dimensions (WxDxH)	43.2 × 60.7 × 8.9 cm 17.0" × 23.9" × 3.5" (2U)	43.2 × 60.7 × 8.9 cm 17.0" × 23.9" × 3.5" (2U)
Weights	37 kg (81.5 lb)	42.5 kg (93 lb)

Table 8. Environmental and Safety

	120V Models	208V Models	230V Models
Operating Temperature	0°C to 40°C (32°F to 104°F) Optimal battery performance: 25°C (77°F)		
Storage Temperature	0°C to 25°C (32°F to 77°F)		
Transit Temperature	-25°C to 55°C (-13°F to 131°F)		
Relative Humidity	5–95% noncondensing		
Operating Altitude	Up to 3,000 meters above sea level		
Transit Altitude	Up to 10,000 meters above sea level		
Audible Noise	Less than 45 dBA Normal mode, typical load Less than 50 dBA Battery mode		
Surge Suppression	IEEE C62.41 Category B	IEEE C62.41 Category B IEC 61000-4-5	IEC 61000-4-5
Safety Conformance	UL 1778, UL 497A CSA C22.2, No. 107.1, 107.2 NOM-019-SCFI	UL 1778, UL 497A NOM-019-SCFI IEC 60950-1; EN 62040-1-1	IEC 60950-1; EN 62040-1-1
Agency Markings	cULus, NOM-NYCE	cULus, NOM-NYCE, CE, TÜV-GS (G models only)	CE, TÜV-GS
EMC (Class A)	FCC Part 15, ICES-003	FCC Part 15, ICES-003	EN 50091-2, IEC 62040-2

Table 9. Battery

UPS Configuration	(6) 12V, 9 Ah internal batteries
EBM Configuration	PW9125 72 EBM: (12) 12V, 9 Ah (2 strings of 6 batteries in parallel)
Type	Sealed, maintenance-free, valve-regulated, lead-acid
Charging	Internal battery: approximately 3 hours to 90% usable capacity at nominal line voltage after full load discharge External battery: no more than 20x discharge time to 90% usable capacity at nominal line voltage after full load discharge
Monitoring	Advanced monitoring for earlier failure detection and warning; auto detection of additional EBMs

Table 10. Battery Runtimes (in Minutes at Full/Half Load)

Model	UPS Internal Batteries	1 EBM	2 EBMs	3 EBMs	4 EBMs
2500 VA/1750W	7/16	28/57	48/90	68/150	88/200
3000 VA/2100W	5/13	25/55	38/72	54/120	70/160

NOTE Battery times are approximate and vary depending on the load configuration and battery charge.

Chapter 9 Troubleshooting

This section explains:

- UPS alarms and conditions
- How to silence an alarm
- Service and support

Audible Alarms and UPS Conditions

The UPS has an audible alarm feature to alert you of potential power problems. Use Table 11 to determine and resolve the UPS alarms and conditions.



NOTE Some alarms, such as the *Overtemperature* and *Overload* alarms, must be cleared by shutting down and restarting the UPS (see page 65 for more information).

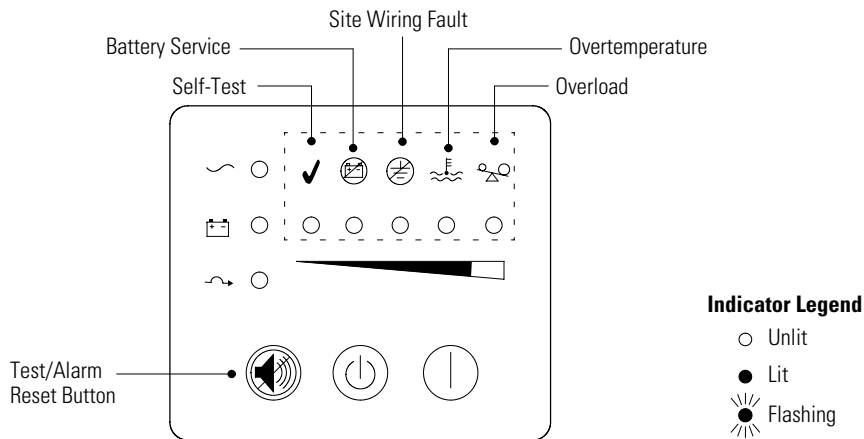

Figure 46. Alarm Indicators

Silencing an Audible Alarm

Before silencing an alarm, check the alarm condition and perform the applicable action to resolve the condition (see Table 11).















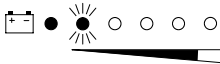

To silence the alarm for an existing fault, press the  button. If UPS status changes, the alarm beeps, overriding the previous alarm silencing.

Table 11. Troubleshooting Guide

Alarm or Condition	Possible Cause	Action
The  indicator is not on; the UPS does not start.	The power cord is not connected correctly.	Check the power cord connections.
	The wall outlet is faulty.	Have a qualified electrician test and repair the outlet.
	The main utility breaker is off.	Verify that the main utility breaker is on.
	The remote emergency power-off (REPO) switch is active.	Reset the REPO switch and restart the UPS.
	The REPO connector is missing.	Verify that the REPO connector is installed on the rear panel.
The  indicator is flashing; power is not available at the UPS output receptacles.	The UPS is in Standby mode.	Press the On button to supply power to the connected equipment.
The UPS operates normally, but some or all of the protected equipment is not on.	The equipment is not connected to the UPS correctly.	Verify that the equipment is plugged into the UPS receptacles. For hardwired models, contact a qualified electrician to check connections to the power source.
	The output receptacle circuit breaker (if applicable) is open.	Check the load. Disconnect faulty load equipment. Wait several minutes before resetting the UPS circuit breaker.
	One of the load segments has been turned off through the power management software.	Reactivate the segment with the software.
The UPS does not provide the expected backup time.	The batteries need charging or service.	Plug the UPS into a power outlet (apply utility power on hardwired models) for 24 hours to charge the batteries. After charging the batteries, press and hold the  button for 3 seconds; then check the  indicator. If the  indicator is still flashing, see "Replacing Batteries" on page 52.
 ● Battery Intermittent audible alarm	The UPS is on battery (see "Battery Mode" on page 39 for more information).	The UPS is powering the equipment with battery power. Check the bar graph indicators for available battery capacity and prepare your equipment for shutdown.
 ● ●  ○ ○ ○ Warning - Low Battery	Three-minute battery warning.	Three minutes or less of battery power remains (depending on load configuration and battery charge). Save your work and turn off your equipment.

Alarm or Condition	Possible Cause	Action
 <p>Shutdown - Low Battery</p>	Shutdown imminent.	Prepare equipment for shutdown.
 <p>Bypass</p>	The UPS is in Bypass mode.	The equipment is transferred to utility power; however, the utility power continues to be passively filtered by the UPS. Check for one of the following alarms: Overtemperature, Overload, UPS Failure, or Battery Service.
 <p>Bypass</p>	Bypass is not available. Input voltage is not within $\pm 12\%$ of nominal or input frequency is not within $\pm 3\%$ of nominal.	The UPS is receiving utility power that may be unstable or in brownout conditions. The UPS continues to supply power to your equipment. If conditions worsen, the UPS may switch to battery power.
 <p>Battery Service</p>	The batteries may be fully discharged.	Plug the UPS into a power outlet (apply utility power on hardwired models) for 24 hours to charge the batteries. After charging the batteries, press and hold the  button for 3 seconds; then check the  indicator. If the  indicator is still flashing, see "Replacing Batteries" on page 52.
	The batteries are not connected correctly.	Check the battery connections. Call your service representative if the problem persists.
 <p>Site Wiring Fault (120V models only)</p>	Ground wire connection does not exist or the line and neutral wires are reversed in the wall outlet.	Have a qualified electrician correct the wiring. To disable this alarm, see "Configuration Mode" on page 41.
 <p>Overtemperature</p>	The UPS internal temperature is too high. The UPS transfers to Bypass mode, allowing the UPS to cool.	Turn off the UPS. Unplug or remove utility power from the UPS. Clear vents and remove any heat sources. Ensure the airflow around the UPS is not restricted. Wait at least 5 minutes and restart the UPS. If the condition persists, contact your service representative.
 <p>Overload Continuous audible alarm</p>	Power requirements exceed UPS capacity (101–150% for 30 seconds) or the load is defective.	Turn off the UPS. Unplug or remove utility power from the UPS. Remove some of the equipment from the UPS. Wait at least 5 seconds until all indicators are off and restart the UPS. If the overload condition persists (101–110% for 2 minutes or 111–150% for 30 seconds), the UPS automatically shuts down.

Service and Support

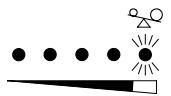
If you have any questions or problems with the UPS, call your **Local Distributor** or the **Help Desk** at one of the following telephone numbers and ask for a UPS technical representative.

United States: **1-800-356-5737** or **1-919-870-3149**
Canada: **1-800-461-9166 ext 260**
All other countries: **Call your local service representative**

Please have the following information ready when you call the Help Desk:

- Model number
- Serial number
- Version number (if available)
- Date of failure or problem
- Symptoms of failure or problem
- Customer return address and contact information

If repair is required, you will be given a Returned Material Authorization (RMA) Number. This number must appear on the outside of the package and on the Bill Of Lading (if applicable). Use the original packaging or request packaging from the Help Desk or distributor. Units damaged in shipment as a result of improper packaging are not covered under warranty. A replacement or repair unit will be shipped, freight prepaid for all warrantied units.



NOTE For critical applications, immediate replacement may be available. Call the **Help Desk** for the dealer or distributor nearest you.

Chapter 10 Warranty

Two-Year Limited Warranty (US and Canada)

Powerware UPS Models: 3105, 3110, 3115, 9104, 9120, 9125, and FERRUPS® up to 3.1 kVA

WARRANTOR: The warrantor for the limited warranties set forth herein is Eaton Power Quality Corporation, a Delaware Corporation company (“Company”).

LIMITED WARRANTY: This limited warranty (this “Warranty”) applies only to the original End-User (the “End-User”) of any Powerware 3105, 3110, 3115, 9104, 9120, 9125, and FERRUPS up to 3.1 kVA Products (individually and collectively, the “Product”) purchased on or after June 1, 2004 and cannot be transferred. This Warranty applies even in the event that the Product is initially sold by Company for resale to an End-User.

LIMITED WARRANTY PERIOD: The period covered by this Warranty for Product installed [and currently located] in the fifty (50) United States, the District of Columbia, and Canada is twenty-four (24) months from the date of purchase.

WHAT THIS LIMITED WARRANTY COVERS: The warrantor warrants that the Product and battery (individually and collectively, the “Warranted Items”) are free from defects in material and workmanship. If, in the opinion of Company, a Warranted Item is defective and the defect is within the terms of this Warranty, Company’s sole obligation will be to repair or replace such defective Warranted Item (including by providing service, parts and labor, as applicable), at the option of Company.

PROCEDURES FOR REPAIR OR REPLACEMENT OF WARRANTED ITEMS: The Warranted Item will be repaired or replaced at a Company site or such other location as determined by Company.

If the Warranted Item is to be replaced by Company, and the End-User supplies a credit card number or purchase order for the value of the replacement Product, Company will use commercially reasonable business efforts to ship (via standard ground shipment and at no cost to the End-User) the replacement Warranted Item to the End-User within one (1) business day after Company receives notice of the warranty claim. In such case, the End-User must return (at Company’s expense) the defective Warranted Item to Company in the same packaging as the replacement Warranted Item received by the End-User or as otherwise instructed by Company. If Company does not receive the defective Warranted Item, Company will either charge the End-User’s credit card, or send the End-User an invoice (which the End-User agrees to pay), for the value of the replacement Product.

If the Warranted Item is to be replaced by Company, but the End-User is unwilling or unable to supply a credit card number or purchase order for the value of the replacement Product, Company will use commercially reasonable business efforts to ship (via standard ground shipment and at no cost to the End-User) the replacement Warranted Item to the End-User within one (1) business day after Company receives the defective Product from the End-User.

In any case, Company will provide shipping instructions and will pay its designated carrier for all shipping charges for return of defective equipment and replacement of Warranted Items. Any returned Warranted Item or parts that are replaced may be new or reconditioned. All Warranted Items returned to Company and all parts replaced by Company shall become the property of Company.

WHAT THIS LIMITED WARRANTY DOES NOT COVER: This Warranty does not cover any defects or damages caused by: (a) failure to properly store the Product before installation, including the charge of batteries no later than the date indicated on the packaging; (b) shipping and delivery of the Product if shipping is FOB Factory; (c) neglect, accident, abuse, misuse, misapplication, or incorrect installation; (d) repair or alteration not authorized in writing by Company personnel or performed by an authorized Company Customer Service Engineer or Agent; (e) improper testing, operation, maintenance, adjustment, or modification of any kind not authorized in writing by Company personnel or performed by an authorized Company Customer Service Engineer or Agent; or (f) use of the Product under other than normal operating conditions or in a manner inconsistent with the Product's labels or instructions.

This Warranty is not valid if the Product's serial numbers have been removed or are illegible. Any Warranted Items repaired or replaced pursuant to this Warranty will be warranted for the remaining portion of the original Warranty subject to all the terms thereof.

Company shall not be responsible for any charges for testing, checking, removal or installation of Warranted Items.

COMPANY DOES NOT WARRANT EQUIPMENT NOT MANUFACTURED BY COMPANY. IF PERMITTED BY THE APPLICABLE MANUFACTURER, COMPANY SHALL PASS THROUGH SUCH MANUFACTURER'S WARRANTIES TO END-USER.

COMPANY DOES NOT WARRANT SOFTWARE, INCLUDING SOFTWARE EMBEDDED IN PRODUCTS, THAT IS NOT CREATED BY COMPANY. WITHOUT LIMITING THE FOREGOING, COMPANY SPECIFICALLY DOES NOT WARRANT SOFTWARE (SUCH AS LINUX) THAT WAS CREATED USING AN "OPEN SOURCE" MODEL OR IS DISTRIBUTED PURSUANT TO AN OPEN SOURCE LICENSE.

THIS WARRANTY IS THE SOLE AND EXCLUSIVE WARRANTY OFFERED BY COMPANY WITH RESPECT TO THE PRODUCTS AND SERVICES AND, EXCEPT FOR SUCH FOREGOING WARRANTY COMPANY DISCLAIMS ALL OTHER WARRANTIES INCLUDING BUT NOT LIMITED TO ANY IMPLIED WARRANTIES OF MERCHANTABILITY, TITLE, NON-INFRINGEMENT, AND FITNESS FOR A PARTICULAR PURPOSE. CORRECTION OF NON-CONFORMITIES IN THE MANNER AND FOR THE PERIOD OF TIME PROVIDED ABOVE SHALL CONSTITUTE COMPANY'S SOLE LIABILITY AND END-USER'S EXCLUSIVE REMEDY FOR FAILURE OF COMPANY TO MEET ITS WARRANTY OBLIGATIONS, WHETHER CLAIMS OF THE END-USER ARE BASED IN CONTRACT, IN TORT (INCLUDING NEGLIGENCE OR STRICT LIABILITY), OR OTHERWISE.

LIMITATION OF LIABILITY: The remedies of the End-User set forth herein are exclusive and are the sole remedies for any failure of Company to comply with its obligations hereunder. In no event shall Company be liable in contract, in tort (including negligence or strict liability) or otherwise for damage to property or equipment other than the Products, including loss of profits or revenue, loss of use of Products, loss of data, cost of capital, claims of customers of the End-User or any special, indirect, incidental or consequential damages whatsoever. The total cumulative liability of Company hereunder whether the claims are based in contract (including indemnity), in tort (including negligence or strict liability) or otherwise, shall not exceed the price of the Product on which such liability is based.

Company shall not be responsible for failure to provide service or parts due to causes beyond Company's reasonable control.

END-USER'S OBLIGATIONS: In order to receive the benefits of this Warranty, the End-User must use the Product in a normal way; follow the Product's user's guide; and protect against further damage to the Product if there is a covered defect.

OTHER LIMITATIONS: Company's obligations under this Warranty are expressly conditioned upon receipt by Company of all payments due to it (including interest charges, if any). During such time as Company has not received payment of any amount due to it for the Product, in accordance with the contract terms under which the Product is sold, Company shall have no obligation under this Warranty. Also during such time, the period of this Warranty shall continue to run and the expiration of this Warranty shall not be extended upon payment of any overdue or unpaid amounts.

COSTS NOT RELATED TO WARRANTY: The End-User shall be invoiced for, and shall pay for, all services not expressly provided for by the terms of this Warranty, including without limitation, site calls involving an inspection that determines no corrective maintenance is required. Any costs for replacement equipment, installation, materials, freight charges, travel expenses or labor of Company representatives outside the terms of this Warranty will be borne by the End-User.

OBTAINING WARRANTY SERVICE: In the USA, call the Customer Reliability Center 7x24 at 800-356-5737. Outside of the USA, call your local Powerware product sales or service representative, or call the Customer Reliability Center in the USA at 919-870-3149. For comments or questions about this Warranty, write to the Customer Quality Representative, 3301 Spring Forest Road, Raleigh, North Carolina 27616 USA.

Ten-Year Pro-Rated Limited Warranty (US and Canada)

Powerware UPS Models: 5115, 5125, 5140, 9104, 9120, 9125, 9155, 9170+, and FERRUPS

WARRANTOR: The warrantor for the limited warranties set forth herein is Eaton Power Quality Corporation, a Delaware Corporation company ("Company").

LIMITED WARRANTY: This pro-rated limited warranty (this "Warranty") applies only to the original End-User (the "End-User") of any Powerware 5115, 5125, 5140, 9104, 9120, 9125, 9155, 9170+, and FERRUPS Products (individually and collectively, the "Product") and cannot be transferred. This Warranty applies even in the event that the Product is initially sold by Company for resale to an End-User.

WHAT THIS WARRANTY COVERS: In addition to the standard Two-Year Limited Warranty covering the applicable Product, the warrantor warrants that the Product will have a service life (defined below) of ten years from the date of purchase (the "Ten-Year Service Life") when used in accordance with the storage, handling, installation, operation and maintenance procedures prescribed in the Product's user's guide. "Service life" means the Product's ability to deliver at least 80% of its original rated backup time.

If Company finds, in its sole discretion, that any Product has not provided the Ten-Year Service Life, Company will, as its sole obligation and the End-User's sole remedy for Company's breach of this warranty, repair or replace the Product, at its option, F.O.B. Company's factory, for a charge, payable by the End-User to Company pro-rated on the following basis:

The End-User will be allowed a credit against Company's list price of equivalent equipment at the time of return of the Product to Company, in proportion to the percentage of Ten-Year Service Life remaining at the time of return of the Product to Company. In calculating the available credit, the remaining portion of the Ten-Year Service Life will be rounded up or down to the nearest whole year. The End-User will assume responsibility to pay the balance of the list price; and Company reserves the right to require payment prior to delivery of the repaired or replacement equipment.

For the avoidance of doubt, Company's responsibilities under this Warranty are as follows:

- Years 1-2 - Product repaired or replaced pursuant to terms of Limited Warranty
- Years 3-10 - Unit Credit (\$) = Current List Price \times $\frac{\text{Years of Unexpired Life}}{10 \text{ Years of Warranted Life}}$

WHAT THIS LIMITED WARRANTY DOES NOT COVER: This Warranty does not cover any defects or damages caused by: (a) failure to properly store the Product before installation, including the charge of batteries no later than the date indicated on the packaging; (b) shipping and delivery of the Product if shipping is FOB Factory; (c) neglect, accident, abuse, misuse, misapplication, or incorrect installation; (d) repair or alteration not authorized in writing by Company personnel or performed by an authorized Company Customer Service Engineer or Agent; (e) improper testing, operation, maintenance, adjustment, or modification of any kind not authorized in writing by Company personnel or performed by an authorized Company Customer Service Engineer or Agent; or (f) use of the Product under other than normal operating conditions or in a manner inconsistent with the Product's labels or instructions.

This Warranty is not valid: (a) unless the End-User returns to Company the Warranty Registration Card within thirty (30) days of purchase; or (b) if the Product's serial numbers have been removed or are illegible. Any Warranted Items repaired or replaced pursuant to this Warranty will be warranted for the remaining portion of the original Warranty subject to all the terms thereof.

Company shall not be responsible for any charges for testing, checking, removal or installation of Warranted Items.

COMPANY DOES NOT WARRANT EQUIPMENT NOT MANUFACTURED BY COMPANY. IF PERMITTED BY THE APPLICABLE MANUFACTURER, COMPANY SHALL PASS THROUGH SUCH MANUFACTURER'S WARRANTIES TO END-USER.

COMPANY DOES NOT WARRANT SOFTWARE, INCLUDING SOFTWARE EMBEDDED IN PRODUCTS, THAT IS NOT CREATED BY COMPANY. WITHOUT LIMITING THE FOREGOING, COMPANY SPECIFICALLY DOES NOT WARRANT SOFTWARE (SUCH AS LINUX) THAT WAS CREATED USING AN "OPEN SOURCE" MODEL OR IS DISTRIBUTED PURSUANT TO AN OPEN SOURCE LICENSE.

THIS WARRANTY IS THE SOLE AND EXCLUSIVE WARRANTY OFFERED BY COMPANY WITH RESPECT TO THE PRODUCTS AND SERVICES AND, EXCEPT FOR SUCH FOREGOING WARRANTY COMPANY DISCLAIMS ALL OTHER WARRANTIES INCLUDING BUT NOT LIMITED TO ANY IMPLIED WARRANTIES OF MERCHANTABILITY, TITLE, NON-INFRINGEMENT, AND FITNESS FOR A PARTICULAR PURPOSE. CORRECTION OF NON-CONFORMITIES IN THE MANNER AND FOR THE PERIOD OF TIME PROVIDED ABOVE SHALL CONSTITUTE COMPANY'S SOLE LIABILITY AND END-USER'S EXCLUSIVE REMEDY FOR FAILURE OF COMPANY TO MEET ITS WARRANTY OBLIGATIONS, WHETHER CLAIMS OF THE END-USER ARE BASED IN CONTRACT, IN TORT (INCLUDING NEGLIGENCE OR STRICT LIABILITY), OR OTHERWISE.

LIMITATION OF LIABILITY: The remedies of the End-User set forth herein are exclusive and are the sole remedies for any failure of Company to comply with its obligations hereunder. In no event shall Company be liable in contract, in tort (including negligence or strict liability) or otherwise for damage to property or equipment other than the Products, including loss of profits or revenue, loss of use of Products, loss of data, cost of capital, claims of customers of the End-User or any special, indirect, incidental or consequential damages whatsoever. The total cumulative liability of Company hereunder whether the claims are based in contract (including indemnity), in tort (including negligence or strict liability) or otherwise, shall not exceed the price of the Product on which such liability is based.

Company shall not be responsible for failure to provide service or parts due to causes beyond Company's reasonable control.

END-USER'S OBLIGATIONS: In order to receive the benefits of this Warranty, the End-User must use the Product in a normal way; follow the Product's operation and maintenance manual; and protect against further damage to the Product if there is a covered defect.

OTHER LIMITATIONS: Company's obligations under this Warranty are expressly conditioned upon receipt by Company of all payments due to it (including interest charges, if any). During such time as Company has not received payment of any amount due to it for the Product, in accordance with the contract terms under which the Product is sold, Company shall have no obligation under this Warranty. Also during such time, the period of this Warranty shall continue to run and the expiration of this Warranty shall not be extended upon payment of any overdue or unpaid amounts.

COSTS NOT RELATED TO WARRANTY: The End-User shall be invoiced for, and shall pay for, all services not expressly provided for by the terms of this Warranty, including without limitation, site calls involving an inspection that determines no corrective maintenance is required. Any costs for replacement equipment, installation, materials, freight charges, travel expenses or labor of Company representatives outside the terms of this Warranty will be borne by the End-User.

OBTAINING WARRANTY SERVICE: In the USA, call the Customer Reliability Center 7x24 at 800-356-5737. Outside of the USA, contact your local Powerware product sales or service representative, or call the Customer Reliability Center in the USA at 919-870-3149. Company will not accept any Product for return, credit or exchange unless expressly authorized by Company in writing and delivered FOB Company factory. For comments or questions about this Warranty, write to the Customer Quality Representative, 3301 Spring Forest Road, Raleigh, North Carolina 27616 USA.

Load Protection Guarantee (US and Canada)

Powerware UPS Models 3105, 3110, 3115, 5110, 5115, 5125, 9120, 9125, 9150, 9155, 9170+, and FERRUPS

GUARANTOR: The Guarantor for the load protection guaranty set forth herein is Eaton Power Quality Corporation, a Delaware Corporation company ("Company").

LIMITED GUARANTY: This load protection guaranty (this "Guaranty") applies only to the original End-User (the "End-User") of any Powerware 3105, 3110, 3115, 5110, 5115, 5125, 9120, 9125, 9150, 9155, 9170+, and FERRUPS Products (individually and collectively, the "Product") and cannot be transferred. This Guaranty applies even in the event that the Product is initially sold by Company for resale to an End-User.

WHAT THIS GUARANTY COVERS: For the lifetime of the Product, Guarantor promises to repair or replace, at Guarantor's option, the equipment (valued up to the limits shown below*) that is damaged by an AC power line surge, spike, or other transient when properly connected to Guarantor's uninterruptible power system ("UPS"). Reimbursement for or restoration of data loss excluded. This Guaranty applies only if all of the following circumstances arise:

1. The UPS is plugged into properly grounded and wired outlets, using no extension cords, adapters, other ground wires or other electrical connectors;
2. The installation of the UPS complies with all applicable electrical and safety codes described by the National Electric Code (NEC);
3. The UPS was used under normal operating conditions and in accordance with all labels and instructions; and
4. The UPS was not damaged by accident (other than AC power line transient), misuse, or abuse.

***Cumulative Limits to be paid by Guarantor under this Load Protection Guaranty:**

- \$25,000 for Powerware UPS Models 3105, 3110, and 3115
- \$150,000 for Powerware UPS Models 5110, 5115, and 5125
- \$250,000 for Powerware UPS Models 9120, 9125, 9150, 9155, 9170+, and FERRUPS products

WHAT THIS GUARANTY DOES NOT COVER: Any reimbursement or repair to End-User's equipment does not include reimbursement for or restoration of any data loss. This Guaranty does not cover any defects or damages caused by: (a) failure to properly store the Product before installation, including the charge of batteries no later than the date indicated on the packaging; (b) shipping and delivery of the Product if shipping is FOB Factory; (c) neglect, accident, abuse, misuse, misapplication, or incorrect installation of Product; (d) repair or alteration of Product not authorized in writing by Company personnel or performed by an authorized Company Customer Service Engineer or Agent; (e) improper testing, operation, maintenance, adjustment, or modification of any kind to the Product not authorized in writing by Company personnel or performed by an authorized Company Customer Service Engineer or Agent; or (f) use of the Product under other than normal operating conditions or in a manner inconsistent with the Product's labels or instructions.

This Guaranty is not valid: (a) unless the End-User returns to Company the Warranty Registration Card within thirty (30) days of purchase; or (b) if the Product's serial numbers have been removed or are illegible.

Company shall not be responsible for any charges for testing, checking, removal or installation of any items.

LIMITATION OF LIABILITY: THE REMEDIES OF THE END-USER SET FORTH HEREIN ARE EXCLUSIVE AND ARE THE SOLE REMEDIES FOR ANY FAILURE OF COMPANY TO COMPLY WITH ITS OBLIGATIONS HEREUNDER. EXCEPT AS OTHERWISE PROVIDED FOR IN THIS GUARANTY, IN NO EVENT SHALL COMPANY BE LIABLE IN CONTRACT, IN TORT (INCLUDING NEGLIGENCE OR STRICT LIABILITY) OR OTHERWISE FOR DAMAGE TO PROPERTY OR EQUIPMENT OTHER THAN THE PRODUCTS, INCLUDING LOSS OF PROFITS OR REVENUE, LOSS OF USE OF PRODUCTS, LOSS OF DATA, COST OF CAPITAL, CLAIMS OF CUSTOMERS OF THE END-USER OR ANY SPECIAL, INDIRECT, INCIDENTAL OR CONSEQUENTIAL DAMAGES WHATSOEVER. THE TOTAL CUMULATIVE LIABILITY OF COMPANY HEREUNDER WHETHER THE CLAIMS ARE BASED IN CONTRACT (INCLUDING INDEMNITY), IN TORT (INCLUDING NEGLIGENCE OR STRICT LIABILITY) OR OTHERWISE, SHALL NOT EXCEED THOSE SET FORTH ABOVE.

Company shall not be responsible for failure to provide repair or replacement under this Guaranty due to causes beyond Company's reasonable control.

END-USER'S OBLIGATIONS: In order to receive the benefits of this Guaranty, the End-User must use the Product in a normal way; follow the Product's operation and maintenance manual; and protect against further damage to the Product if there is a covered defect.

OTHER LIMITATIONS: Company's obligations under this Guaranty are expressly conditioned upon receipt by Company of all payments due to it (including interest charges, if any). During such time as Company has not received payment of any amount due to it for the Product, in accordance with the contract terms under which the Product is sold, Company shall have no obligation under this Guaranty.

COSTS NOT RELATED TO GUARANTY: The End-User shall be invoiced for, and shall pay for, all services not expressly provided for by the terms of this Guaranty, including without limitation, site calls involving an inspection that determines no corrective maintenance is required. Any costs for replacement equipment, installation, materials, freight charges, travel expenses or labor of Company representatives outside the terms of this Guaranty will be borne by the End-User.

TO MAKE A CLAIM: In the USA, call the Customer Reliability Center 7x24 at 800-356-5737. Outside of the USA, contact your local Powerware product sales or service representative, or call the Customer Reliability Center in the USA at 919-870-3149. For comments or questions about this Load Protection Guaranty, write to the Customer Quality Representative, 3301 Spring Forest Road, Raleigh, North Carolina 27616 USA.